



# RANGER® COUNT 1000

Counting Scales



## ***Affordable Counting Scales for Basic Industrial Counting Operations***

Ranger Count 1000 Counting Scales are designed to provide accurate counting results for basic operation in annual inventories, parts rooms, rental and other counting applications. With an internal counting resolution of 1:300,000, Ranger Count 1000 offers accuracy, durability and portability in one practical and surprisingly affordable design.

### ***Standard Features***

- Dedicated counting keypad, with numeric, Tare and Sample keys, makes counting operations simple and straightforward.
- APW memory provides storage for up to ten commonly used part weights, speeding up counting operations and minimizing redundant work.
- Ensure counting accuracy with auto-optimization software that recalculates the Average Piece Weight with each batch of parts.

# RANGER® COUNT 1000 Counting Scales

Model	RC11P3	RC11P6	RC11P15	RC11P30
Default Capacity × Readability	3000 g × 0.2 g 3 kg × 0,0002 kg	6000 g × 0.5 g 6 kg × 0,0005 kg	15000 g × 1 g 15 kg × 0,001 kg	30000 g × 2 g 30 kg × 0,002 kg
Displayed Resolution	1:15,000	1:15,000	1:15,000	1:15,000
Minimum Recommended Sample Weight	2 g	5 g	10 g	20 g
Minimum Recommended APW	0.02 g	0.05 g	0.1 g	0.2 g
Internal Counting Resolution	1:300000			
Construction	Plastic pan with Stainless steel inset, ABS plastic housing			
Weighing Units	g or lb (menu selected)			
Application Modes	Weighing, Counting, Accumulation			
Display	3-Window, backlit LCD 0.75 in / 19 mm High, 6-digit, 7-segment			
Memory	10 locations for APW			
Keypad	7 function, 11 numeric membrane keys			
Zero Range	4 % of full scale capacity			
Tare Range	Full capacity by subtraction			
Stabilization Time	≤ 2 seconds			
Safe Overload Capacity	150 % of capacity			
Power	AC Adapter 12V DC / 1000 mA Internal rechargeable sealed lead acid battery			
Battery Life	80 hours continuous use with 12 hour recharge time			
Calibration	External with kg/g mass, factory calibration recovery			
Operating Temperature Range	0 °C to 40 °C			
Pan Size (W × L)	294 × 226 mm			
Scale Dimensions (W × L × H)	325 × 330.5 × 114 mm			
Shipping Dimensions (W × L × H)	440 × 360 × 160 mm			
Net Weight	4.2 kg			
Shipping Weight	5.3 kg			

## Approvals

- Electrical/Emissions: Meets requirements of approval agencies: UL (adapter), FCC, CE Safety EN61558, EMC EN61326

## Accessory

SST Pan, R11, RC11, A31 ..... 80120009

## Outline Dimensions

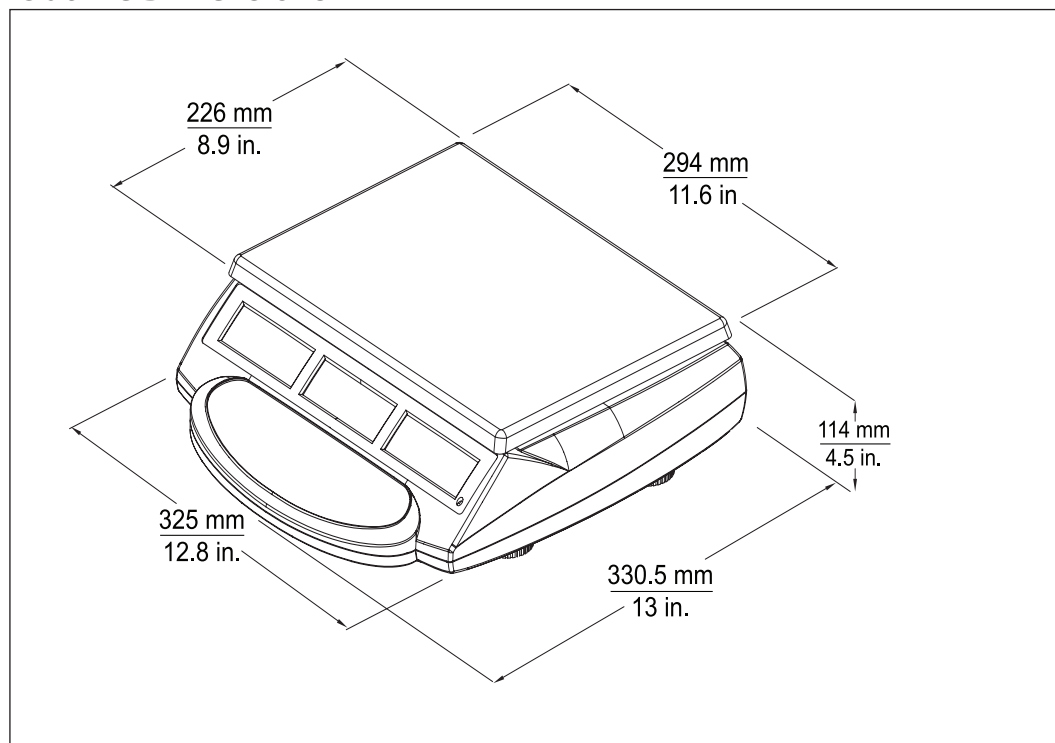

80774768\_C 20191113 © Copyright OHAUS Corporation

**OHAUS Europe GmbH**  
Heuwinkelstrasse 3,  
8606 Nänikon,  
Switzerland

e-mail: [ssc@ohaus.com](mailto:ssc@ohaus.com)  
Tel: 0041 22 567 53 19  
e-mail: [tsc@ohaus.com](mailto:tsc@ohaus.com)  
Tel: 0041 22 567 53 20

[www.ohaus.com](http://www.ohaus.com)

*The management system governing the manufacture of this product is ISO 9001:2015 certified.*

