



GOLDWELD

Exothermic Welding



**CATALOGUE
GOLDWELD**

CATALOGUE GOLDWELD



GOLDWELD Exothermic Welding Mould is made of graphite with high heat resistance. It is specially designed for joining dissimilar metals. GOLDWELD Exothermic welding is the universally approved method for manufacturing enduring copper-to-copper and copper-to-steel electrical connections. Exothermic weld is a effortless, profitable and durable welding connection that adopt a high-temperature exothermic reaction to invent a molecular bond. The conductors are joined by the resulting product of the main reaction when it gets to the solid state.

Moulds shall be made from a graphite material capable of withstanding high temperatures that are capa of providing an average life of not less than SEVENTY (70) times separate exothermic welds SHOULD FOLLOWED as per the manual .

CATALOGUE GOLDWELD

















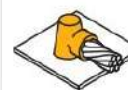

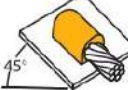









GOLDWELD Exothermic Welding Powder is a powdered weld metal, comprised of copper and aluminium. Exothermic weld is a effortless, profitable and durable welding connection that adopt a high-temperature exothermic reaction to invent a molecular bond. The reaction reaches temperatures over 1500°C thus achieving the fusion of the materials to be welded. Material can be permanently joined within seconds. The conductors are joined by the resulting product of the main reaction when it gets to the solid state. Exothermic Welding does not corrode oxide or degrade with time and is resistant to galvanic coupling. Exothermic Welding offers a permanent welding and a low resistance connection, essential for achieving longwearing and trustworthy results in earthings. Exothermic Welding has an excellent corrosion resistance.

Code	GW15	GW25	GW32	GW45	GW65	GW90	GW115	GW150	GW200	GW250
Size	15g	25g	32g	45g	65g	90g	115g	150g	200g	250g
Tubes/box	40	20	20	20	10	10	10	10	10	10

Selection Chart

Cable to Steel



















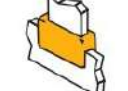



 CS1F	 CS2F	 CS3F	 CS4F	 CS5NC	 CS6F	 CS7N	 CS8N
 CS9N	 CS11NC	 CS12N	 CS13N	 CS14N	 CS15N	 CS16	 CS18N
 CS21NC	 CS22	 CS23F	 CS24F	 CS25N	 CS26N	 CS27N	 CS28FC
 CS29N	 CS30NC	 CS31F	 CS42FC	 CS43FC			

Note : CS_n - | None
 C | Cast iron
 N = On surface
 F = Off surface

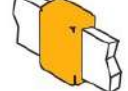



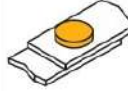

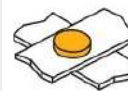

Cable to Pipe



Bus Bar to Bus Bar

















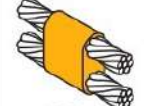





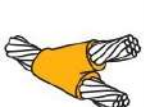







 BB1	 BB2	 BB3	 BB4	 BB5	 BB6	 BB7	 BB8
 BB11	 BB12	 BB14	 BB17	 BB20	 BB21	 BB22	 BB27
 BB28	 BB29	 BB40	 BB41	 BB43	 BB44	 BB45	 BB46

Bus Bar to Ground Rod











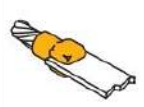



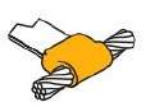
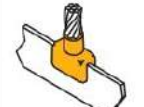







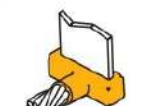
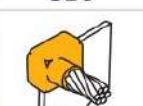

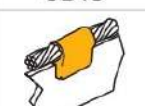

 BR1	 BR2	 BR4	 BR7	 BR8	 BR9	 BR11	 BR12
--	--	--	--	--	---	---	---

Selection Chart

Cable to Cable



























 CC1	 CC2	 CC3	 CC4	 CC5	 CC6	 CC7	 CC8
 CC11	 CC13	 CC14	 CC17	 CC18	 CC19	 CC20	 CC22
 CC23	 CC-24	 CC25	 CC26	 CC27	 CC28	 CC29	 CC30
 CC31	 CC33	 CC34	 CC35	 CC36	 CC37	 CC38	 CC39

Cable to Bus Bar

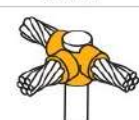





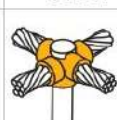

 (Lug) CB1	 CB1	 CB2	 CB3	 CB4	 CB5	 CB6	 CB7
 CB8	 CB9	 CB11	 CB12	 CB15	 CB16	 CB17	 CB18
 CB19	 CB20	 CB21	 CB22	 CB23	 CB24	 CB25	 CB26
 CB27	 CB28	 CB29	 CB30	 CB31	 CB32	 CB34	 CB38

Selection Chart













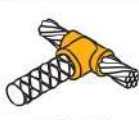

Cable to Ground Rod

 CR1	 CR2	 CR3	 CR5	 CR-6	 CR7	 CR8	 CR9
 CR12	 CR13	 CR14	 CR15	 CR16	 CR17	 CR18	 CR19
 CR20	 CR21	 CR22	 CR23	 CR24	 CR25	 CR26	 CR27
 CR29	 CR30	 CR31	 CR32	 CR33			

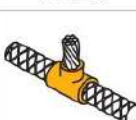
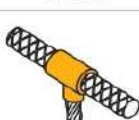

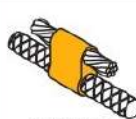
Cable to Rebar (Partially Wrapped)

 CRE1P	 CRE3P	 CRE4P
 CRE5P	 CRE6P	 CRE17P
 CRE18P	 CRE19P	 CRE20P

Cable to Rebar (Fully Wrapped)

 CRE1	 CRE2	 CRE6	 CRE7
 CRE8	 CRE9	 CRE11	 CRE12
 CRE13	 CRE14	 CRE15	 CRE16
 CRE17	 CRE18	 CRE19	 CRE20

Rebar to Rebar

 RE1	 RE2
--	--

Selection Chart

Bus Bar to Steel

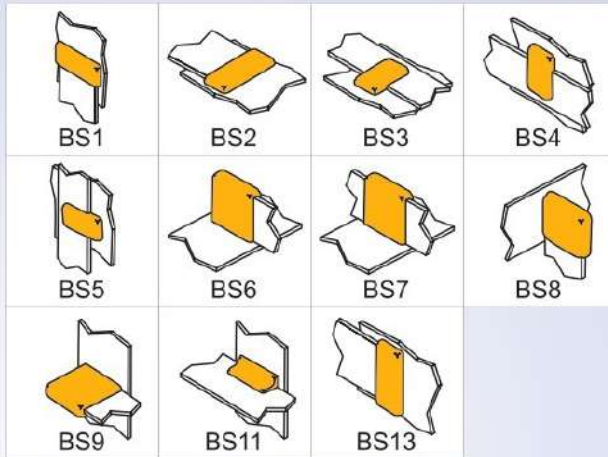

Copper or Steel Stud to Steel

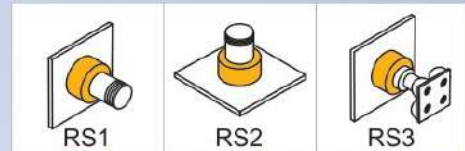

Ground Plates to Cable & Steel

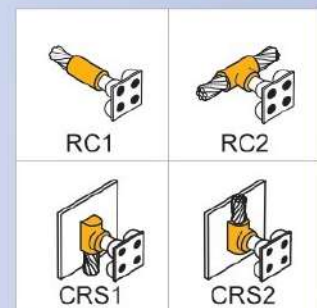

CGR

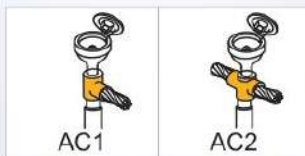

CGRG



AR1

Steel Cable to Steel Rod

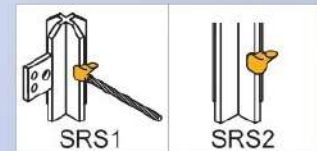

Ground Rod to Ground Rod

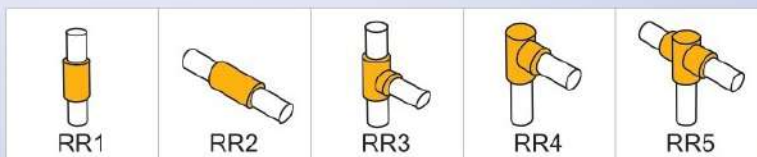

Cathodic Protection

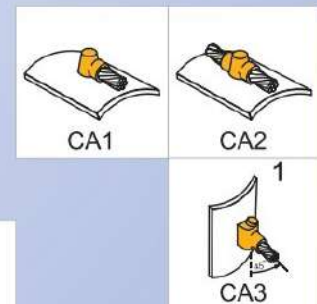

Railway Application

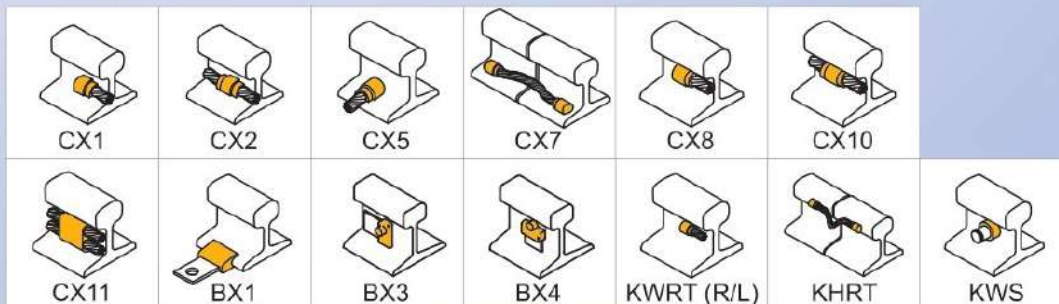

CGR = Cable to Grounding Receptacle
CGRG = Cable & Grounding Receptacle to Ground Rod

BR2

**Bus Bar to
Ground Rod**
Horizontal thru bus
to ground rod

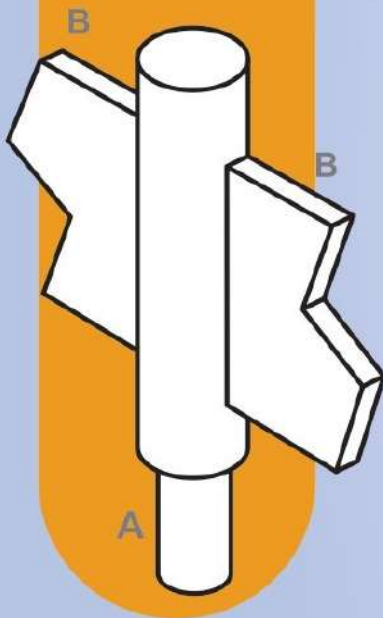

Tools Request :



Rod Size		Conductor Size	Metal Powder (g)	Graphite Mould Type	Handle Clamp Type
A mm	A inch	B mm x mm			
12.7	1/2	20 x 2	65	BR2-N-127202	HCN
		20 x 3	90	BR2-N-127203	HCN
		20 x 4	90	BR2-N-127204	HCN
		25 x 2	65	BR2-N-127252	HCN
		25 x 3	90	BR2-N-127253	HCN
		25 x 4	90	BR2-N-127254	HCN
		30 x 2	90	BR2-C-127302	HCC
		30 x 3	90	BR2-C-127303	HCC
		40 x 3	90	BR2-C-127403	HCC
		50 x 3	115	BR2-C-127503	HCC
14.2;16	5/8	20 x 3	90	BR2-N-16203	HCN
		20 x 4	90	BR2-N-16204	HCN
		20 x 5	115	BR2-N-16205	HCN
		25 x 3	115	BR2-N-16253	HCN
		25 x 4	115	BR2-N-16254	HCN
		25 x 5	150	BR2-C-16255	HCC
		25 x 6	150	BR2-C-16256	HCC
		30 x 2	115	BR2-C-16302	HCC
		30 x 3	115	BR2-C-16303	HCC
		30 x 4	150	BR2-C-16304	HCC
		30 x 5	150	BR2-C-16305	HCC
		30 x 6	150	BR2-C-16306	HCC
		31 x 3	115	BR2-C-16313	HCC
		31 x 6	150	BR2-C-16316	HCC
		38 x 3	150	BR2-C-16383	HCC
		38 x 6	200	BR2-C-16386	HCC
		40 x 3	150	BR2-C-16403	HCC
		40 x 4	150	BR2-C-16404	HCC
		40 x 5	150	BR2-C-16405	HCC
		40 x 6	200	BR2-C-16406	HCC
50 x 3	200	BR2-D-16503	HCD		
50 x 4	200	BR2-D-16504	HCD		
50 x 5	250	BR2-D-16505	HCD		
50 x 6	250	BR2-D-16506	HCD		
17.2;18	3/4	20 x 3	150	BR2-C-18203	HCC
		20 x 4	150	BR2-C-18204	HCC
		25 x 2	150	BR2-C-18252	HCC
		25 x 3	150	BR2-C-18253	HCC
		25 x 4	200	BR2-C-18254	HCC
		25 x 5	200	BR2-C-18255	HCC
		25 x 6	200	BR2-C-18256	HCC
		30 x 2	150	BR2-C-18302	HCC
		30 x 3	150	BR2-C-18303	HCC
		30 x 5	200	BR2-C-18305	HCC
		30 x 6	250	BR2-C-18306	HCC
		31 x 3	200	BR2-C-18313	HCC
		31 x 6	250	BR2-C-18316	HCC
		38 x 3	200	BR2-C-18383	HCC
		38 x 5	200	BR2-C-18385	HCC
		38 x 6	250	BR2-C-18386	HCC
		40 x 3	200	BR2-C-18403	HCC
		40 x 4	200	BR2-C-18404	HCC
		40 x 5	250	BR2-C-18405	HCC
		40 x 6	250	BR2-C-18406	HCC
50 x 3	2x150	BR2-D-18503	HCD		
50 x 4	2x150	BR2-D-18504	HCD		
50 x 5	2x200	BR2-D-18505	HCD		
50 x 6	2x200	BR2-D-18506	HCD		

Rod Size		Conductor Size	Metal Powder (g)	Graphite Mould Type	Handle Clamp Type
A mm	A inch	B mm x mm			
12.7	1/2	20 x 2	65	BR7-E-127202	HCC
		20 x 3	65	BR7-E-127203	HCC
		20 x 4	90	BR7-E-127204	HCC
		25 x 2	65	BR7-E-127252	HCC
		25 x 3	90	BR7-E-127253	HCC
		25 x 4	90	BR7-E-127254	HCC
		30 x 2	65	BR7-E-127302	HCC
		30 x 3	65	BR7-E-127303	HCC
		40 x 3	65	BR7-E-127403	HCC
		50 x 3	65	BR7-E-127503	HCC
14.2	5/8	20 x 3	90	BR7-E-142203	HCC
		20 x 4	115	BR7-E-142204	HCC
		25 x 3	90	BR7-E-142253	HCC
		25 x 4	115	BR7-E-142254	HCC
		25 x 5	150	BR7-E-142255	HCC
		25 x 6	150	BR7-E-142256	HCC
		30 x 2	90	BR7-E-142302	HCC
		30 x 3	90	BR7-E-142303	HCC
		30 x 5	150	BR7-E-142305	HCC
		30 x 6	150	BR7-E-142306	HCC
		40 x 3	90	BR7-E-142403	HCC
		40 x 5	150	BR7-E-142405	HCC
		40 x 6	150	BR7-E-142406	HCC
		50 x 3	90	BR7-E-142503	HCC
		50 x 5	150	BR7-D-142505	HCD
		50 x 6	150	BR7-D-142506	HCD
17.2	3/4	20 x 3	115	BR7-E-172203	HCC
		20 x 4	115	BR7-E-172204	HCC
		25 x 3	115	BR7-E-172253	HCC
		25 x 4	150	BR7-E-172254	HCC
		25 x 6	200	BR7-E-172256	HCC
		30 x 2	115	BR7-E-172302	HCC
		30 x 3	115	BR7-E-172303	HCC
		30 x 5	200	BR7-E-172405	HCC
		30 x 6	200	BR7-E-172306	HCC
		40 x 3	115	BR7-E-172403	HCC
		40 x 5	200	BR7-D-172405	HCC
		40 x 6	200	BR7-D-172406	HCD
		50 x 3	115	BR7-E-172503	HCC
		50 x 5	200	BR7-D-172505	HCD
		50 x 6	200	BR7-D-172506	HCD

BR7

Bus Bar to Ground Rod
Horizontal flat bar thru to ground rod

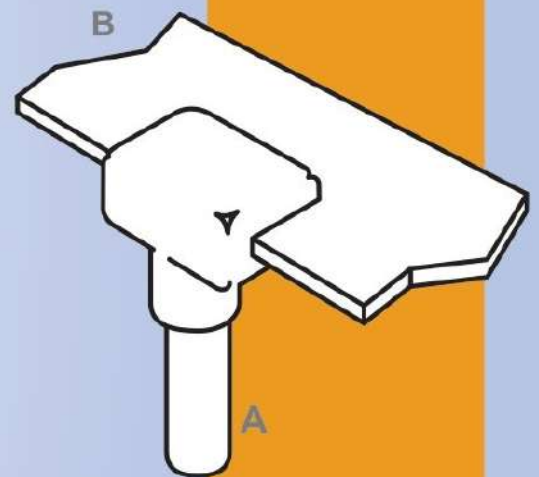

Tools Request :



Mould



Mould brush



Handle clamp



Scraper



Metal powder



Steel disk



Flint igniter



Bus bar brush

CR1

Cable to Ground Rod
Horizontal cable terminal
to ground rod

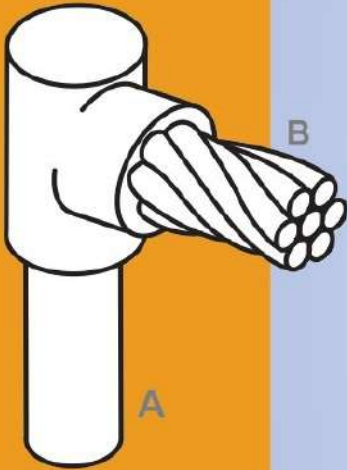

Rod Size		Conductor Size	Metal Powder (g)	Graphite Mould Type	Handle Clamp Type
A _{mm}	A _{inch}	B _{mm²}			
		10	65	CR1-N-12710	HCN
		16	65	CR1-N-12716	HCN
		25	90	CR1-N-12725	HCN
		35	90	CR1-N-12735	HCN
D12.7		50	90	CR1-N-12750	HCN
		70	90	CR1-N-12770	HCN
		95	115	CR1-N-12795	HCN
		120	150	CR1-C-127120	HCC
		10	65	CR1-N-1610	HCN
		16	65	CR1-N-1616	HCN
		25	90	CR1-N-1625	HCN
		35	90	CR1-N-1635	HCN
		50	90	CR1-N-1650	HCN
D14.2, D16		70	90	CR1-N-1670	HCN
		95	90	CR1-N-1695	HCN
		120	115	CR1-C-16120	HCC
		150	115	CR1-C-16150	HCC
		185	150	CR1-C-16185	HCC
		240	150	CR1-D-16240	HCD
		10	65	CR1-N-1810	HCN
		16	65	CR1-N-1816	HCN
		25	90	CR1-N-1825	HCN
		35	90	CR1-N-1835	HCN
		50	90	CR1-N-1850	HCN
		70	90	CR1-N-1870	HCN
D172, D18		95	115	CR1-C-1895	HCC
		120	150	CR1-C-18120	HCC
		150	150	CR1-C-18150	HCC
		185	150	CR1-C-18185	HCC
		240	200	CR1-D-18240	HCD
		300	200	CR1-D-18300	HCD

Tools Request :



Mould



Mould brush



Handle clamp



Scraper



Metal powder



Steel disk



Flint igniter



Bus bar brush

CR2

Cable to Ground Rod
 Horizontal thru cable
 to ground rod

Rod Size		Conductor Size	Metal Powder (g)	Graphite Mould Type	Handle Clamp Type
A _{mm}	A _{Inch}	B _{mm²}			
12.7	1/2	10	65	CR2-N-12710	HCN
		16	65	CR2-N-12716	HCN
		25	90	CR2-N-12725	HCN
		35	90	CR2-N-12735	HCN
		50	90	CR2-N-12750	HCN
		70	90	CR2-N-12770	HCN
		95	115	CR2-N-12795	HCN
		120	150	CR2-C-127120	HCC
14.2;16	5/8	10	65	CR2-N-1610	HCN
		16	65	CR2-N-1616	HCN
		25	90	CR2-N-1625	HCN
		35	90	CR2-N-1635	HCN
		50	90	CR2-N-1650	HCN
		70	115	CR2-N-1670	HCN
		95	115	CR2-N-1695	HCN
		120	150	CR2-C-16120	HCC
		150	200	CR2-C-16150	HCC
		185	200	CR2-C-16185	HCC
172;18	3/4	10	65	CR2-N-1810	HCN
		16	65	CR2-N-1816	HCN
		25	90	CR2-N-1825	HCN
		35	90	CR2-N-1835	HCN
		50	115	CR2-N-1850	HCN
		70	115	CR2-N-1870	HCN
		95	150	CR2-C-1895	HCC
		120	150	CR2-C-18120	HCC
		150	200	CR2-C-18150	HCC
		185	200	CR2-C-18185	HCC
240	250	CR2-D-18240	HCD		
300	150x2	CR2-D-18300	HCD		

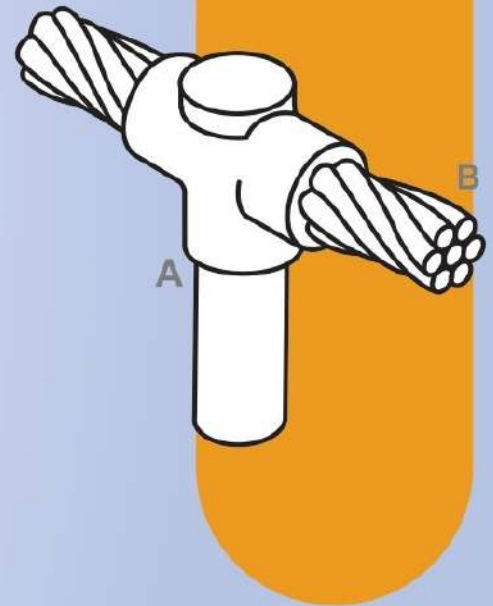

Tools Request :



CR3

Cable to Ground Rod
Horizontal thru cable
to side of ground rod

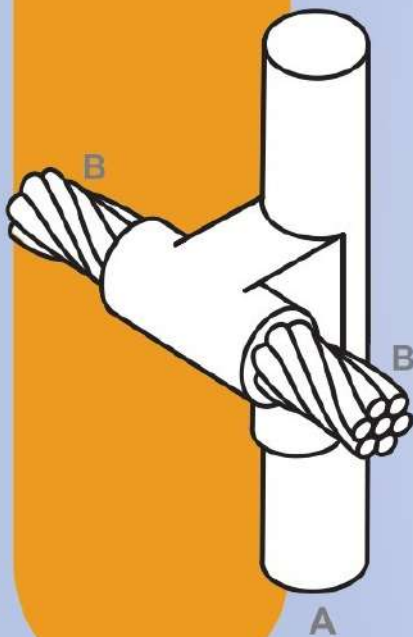

Rod Size		Conductor Size	Metal Powder (g)	Graphite Mould Type	Handle Clamp Type
A mm	A inch	B mm ²			
		10	90	CR3-E-12710	HCC
		16	90	CR3-E-12716	HCC
		25	90	CR3-E-12725	HCC
		35	90	CR3-E-12735	HCC
D12.7		50	115	CR3-E-12750	HCC
		70	115	CR3-E-12770	HCC
		95	150	CR3-E-12795	HCC
		120	150	CR3-E-127120	HCC
		10	90	CR3-E-1610	HCC
		16	90	CR3-E-1616	HCC
		25	90	CR3-E-1625	HCC
		35	90	CR3-E-1635	HCC
		50	115	CR3-E-1650	HCC
D14.2, D16		70	115	CR3-E-1670	HCC
		95	150	CR3-E-1695	HCC
		120	250	CR3-E-16120	HCC
		150	150x2	CR3-D-16150	HCD
		185	150x2	CR3-D-16185	HCD
		240	200x2	CR3-D-16240	HCD
		10	90	CR3-E-1810	HCC
		16	90	CR3-E-1816	HCC
		25	90	CR3-E-1825	HCC
		35	115	CR3-E-1835	HCC
		50	150	CR3-E-1850	HCC
D17.2, D18		70	200	CR3-E-1870	HCC
		95	200	CR3-E-1895	HCC
		120	250	CR3-E-18120	HCC
		150	150x2	CR3-D-18150	HCD
		185	150x2	CR3-D-18185	HCD
		240	200x2	CR3-D-18240	HCD
		300	200x3	CR3-D-18300	HCD

Tools Request :



Mould



Mould brush



Handle clamp



Scraper



Metal powder



Steel disk



Flint igniter



Bus bar brush

CR25

Cable to Ground Rod
Horizontal cable tap and run
to ground rod

Rod Size		Conductor Size		Metal Powder (g)	Graphite Mould Type	Handle Clamp Type		
A _{mm}	A _{inch}	B _{mm}	B _{mm}					
14.2;16	5/8	10	10	65	CR25-E-1610	HCC		
		16	16	90	CR25-E-1616	HCC		
		25	25	90	CR25-E-1625	HCC		
		35	35	115	CR25-E-1635	HCC		
		50	50	150	CR25-E-1650	HCC		
		70	70	150	CR25-E-1670	HCC		
		95	95	150	CR25-E-1695	HCC		
		120	120	200	CR25-E-16120	HCC		
		150	150	200	CR25-E-16150	HCC		
		185	185	250	CR25-D-16185	HCD		
		240	240	150x2	CR25-D-16240	HCD		
		172;18	3/4	10	10	90	CR25-E-1810	HCC
				16	16	90	CR25-E-1816	HCC
				25	25	115	CR25-E-1825	HCC
35	35			115	CR25-E-1835	HCC		
50	50			150	CR25-E-1850	HCC		
70	70			150	CR25-E-1870	HCC		
95	95			200	CR25-E-1895	HCC		
120	120			250	CR25-E-18120	HCC		
150	150			250	CR25-E-18150	HCC		
185	185			150x2	CR25-D-18185	HCD		
240	240			150x2	CR25-D-18240	HCD		
300	300			200x2	CR25-D-18300	HCD		

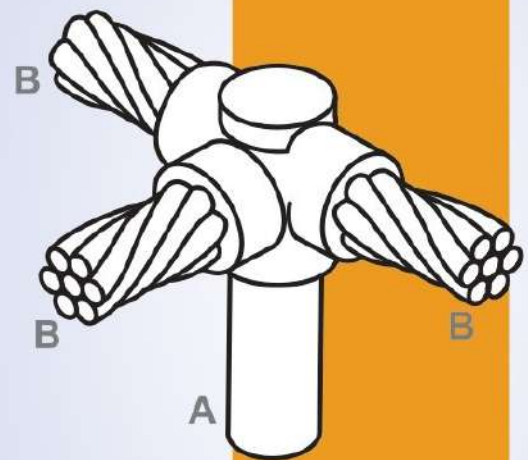

Tools Request :



Mould



Mould brush



Handle clamp



Scraper



Metal powder



Steel disk



Flint igniter



Bus bar brush

CR33

Cable to Ground Rod
Horizontal cable cross
to ground rod

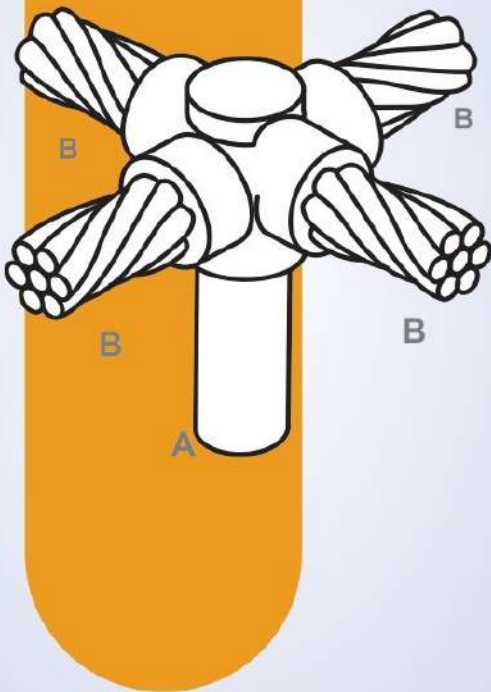

Rod Size		Conductor Size	Metal Powder	Graphite Mould	Handle Clamp
A _{mm}	A _{inch}	B _{mm'}	(g)	Type	Type
14.2	5/8	10	65	CR33-E-1610	HCC
16		16	90	CR33-E-1616	HCC
		25	90	CR33-E-1625	HCC
		35	115	CR33-E-1635	HCC
		50	150	CR33-E-1650	HCC
		70	150	CR33-E-1670	HCC
		95	150	CR33-E-1695	HCC
		120	200	CR33-E-16120	HCC
		150	250	CR33-E-16150	HCC
		185	150x2	CR33-D-16185	HCD
		240	200x2	CR33-D-16240	HCD
17.2	3/4	10	90	CR33-E-1810	HCC
18		16	90	CR33-E-1816	HCC
		25	115	CR33-E-1825	HCC
		35	115	CR33-E-1835	HCC
		50	150	CR33-E-1850	HCC
		70	150	CR33-E-1870	HCC
		95	200	CR33-E-1895	HCC
		120	250	CR33-E-18120	HCC
		150	150x2	CR33-E-18150	HCC
		185	150x2	CR33-D-18185	HCD
		240	200x2	CR33-D-18240	HCD
		300	250x2	CR33-D-18300	HCD

Tools Request :



Mould



Mould brush



Handle clamp



Scraper



Metal powder



Steel disk



Flint igniter



Bus bar brush

Rod Size		Conductor Size	Metal Powder (g)	Graphite Mould Type	Handle Clamp Type
A _{mm}	A _{Inch}	B _{mm²}			
			90	CR17-C-12710	HCC
		16	90	CR17-C-12716	HCC
		25	90	CR17-C-12725	HCC
		35	115	CR17-C-12735	HCC
D12.7	1/2	50	115	CR17-C-12750	HCC
		70	150	CR17-C-12770	HCC
		95	200	CR17-C-12795	HCC
		120	200	CR17-C-127120	HCC
		10	90	CR17-C-1610	HCC
		16	90	CR17-C-1616	HCC
		25	115	CR17-C-1625	HCC
		35	115	CR17-C-1635	HCC
		50	150	CR17-C-1650	HCC
D14.2	5/8	70	200	CR17-C-1670	HCC
D16		95	250	CR17-C-1695	HCC
		120	150x2	CR17-C-16120	HCC
		150	200x2	CR17-D-16150	HCD
		185	200x2	CR17-D-16185	HCD
		240	200x3	CR17-D-16240	HCD
		10	90	CR17-C-1810	HCC
		16	90	CR17-C-1816	HCC
		25	115	CR17-C-1825	HCC
		35	115	CR17-C-1835	HCC
		50	150	CR17-C-1850	HCC
		70	200	CR17-C-1870	HCC
D172	3/4	95	250	CR17-C-1895	HCC
D18		120	150x2	CR17-D-18150	HCD
		120	200x2	CR17-D-18150	HCD
		185	200x2	CR17-D-18185	HCD
		240	200x3	CR17-D-18240	HCD
		300	250x3	CR17-D-18300	HCD

CR17

Cable to Ground Rod
Horizontal run & tap cable
to ground rod

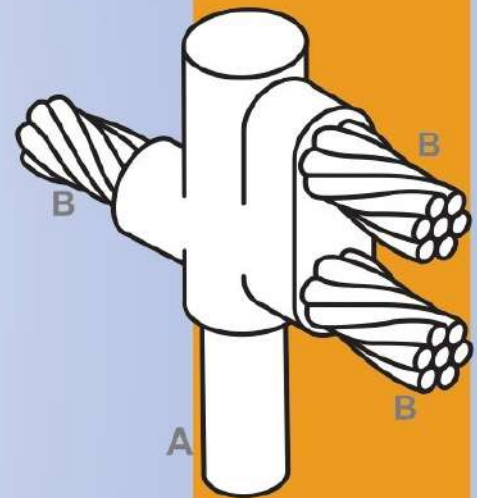

Tools Request :



CR24

Cable to Ground Rod
Horizontal parallel run cab
to ground rod

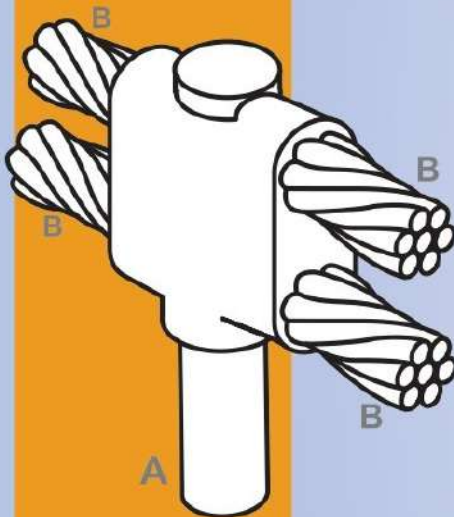

Rod Size		Conductor Size	Metal Powder (g)	Graphite Mould Type	Handle Clamp Type
A _{mm}	A _{inch}	B _{mm²}			
		10	115	CR24-C-12710	HCC
		16	115	CR24-C-12716	HCC
		25	115	CR24-C-12725	HCC
		35	115	CR24-C-12735	HCC
D12.7	1/2	50	150	CR24-C-12750	HCC
		70	200	CR24-C-12770	HCC
		95	250	CR24-C-12795	HCC
		120	150x2	CR24-D-127120	HCD
		10	115	CR24-C-1610	HCC
		16	115	CR24-C-1616	HCC
		25	115	CR24-C-1625	HCC
		35	150	CR24-C-1635	HCC
		50	200	CR24-C-1650	HCC
D14.2	5/8	70	250	CR24-C-1670	HCC
D16		95	150x2	CR24-C-1695	HCC
		120	200x2	CR24-D-16120	HCD
		150	250x2	CR24-D-16150	HCD
		185	250x2	CR24-D-16185	HCD
		240	250x3	CR24-D-16240	HCD
		10	115	CR24-C-1810	HCC
		16	115	CR24-C-1816	HCC
		25	115	CR24-C-1825	HCC
		35	150	CR24-C-1835	HCC
		50	200	CR24-C-1850	HCC
D172	3/4	70	250	CR24-C-1870	HCC
D18		95	150x2	CR24-C-1895	HCC
		120	200x2	CR24-D-18120	HCD
		150	250x2	CR24-D-18150	HCD
		185	250x2	CR24-D-18185	HCD
		240	250x3	CR24-D-18240	HCD
		300	250x3	CR24-D-18300	HCD

Tools Request :



Mould



Mould brush



Handle clamp



Scraper



Metal powder



Steel disk



Flint igniter



Bus bar brush

CC1

Cable to Cable

Horizontal end to end

Conductor Size		Metal Powder (g)	Graphite Mold Type	Handle Clamp Type
A mm ²	B mm ²			
10		15	CC1-N-10	HCN
16		25	CC1-N-16	HCN
25		32	CC1-N-25	HCN
35		45	CC1-N-35	HCN
50		65	CC1-N-50	HCN
70		90	CC1-N-70	HCN
95		90	CC1-N-95	HCN
120		115	CC1-C-120	HCC
150		115	CC1-C-150	HCC
185		150	CC1-C-185	HCC
240		200	CC1-D-240	HCD
300		250	CC1-D-300	HCD
400		150X2	CC1-D-400	HCD
500		200X2	CC1-D-500	HCD

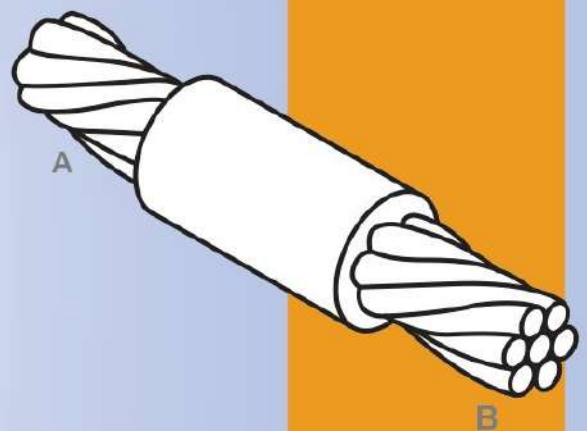

Tools Request :



Mould



Mould brush



Handle clamp



Scraper



Metal powder



Steel disk



Flint igniter



Bus bar brush

CC2

Cable to Cable
Horizontal cable tap
to horizontal cable run

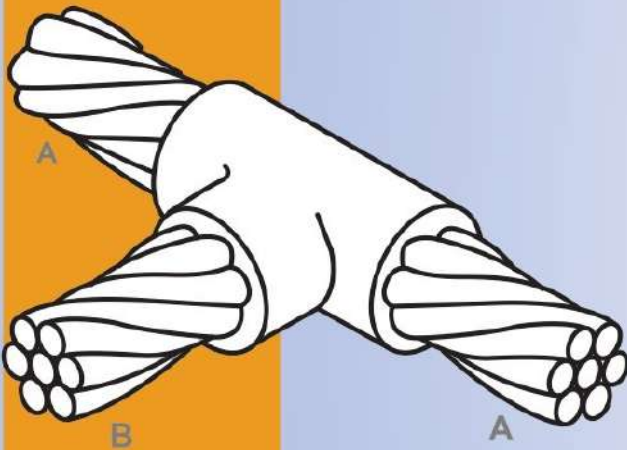

Tools Request :



Conductor Size		Metal Powder (g)	Graphite Mould Type	Handle Clamp Type
A _{mm²}	B _{mm²}			
10	10	25	CC2-N-1010	HCN
16	16	32	CC2-N-1616	HCN
25	25	45	CC2-N-2525	HCN
35	35	45	CC2-N-3535	HCN
35	25	45	CC2-N-3525	HCN
50	50	90	CC2-N-5050	HCN
50	35	45	CC2-N-5035	HCN
50	25	45	CC2-N-5025	HCN
70	70	90	CC2-N-7070	HCN
70	50	90	CC2-N-7050	HCN
70	35	45	CC2-N-7035	HCN
70	25	45	CC2-N-7025	HCN
95	95	115	CC2-N-9595	HCN
95	70	90	CC2-N-9570	HCN
95	50	90	CC2-N-9550	HCN
95	35	90	CC2-N-9535	HCN
95	25	90	CC2-N-9525	HCN
120	120	150	CC2-C-120120	HCC
120	95	150	CC2-C-12095	HCC
120	70	90	CC2-C-12070	HCC
120	50	90	CC2-C-12050	HCC
120	35	90	CC2-C-12035	HCC
120	25	90	CC2-C-12025	HCC
150	150	200	CC2-C-150150	HCC
150	120	150	CC2-C-150120	HCC
150	95	150	CC2-C-15095	HCC
150	70	115	CC2-C-15070	HCC
150	50	115	CC2-C-15050	HCC
150	35	90	CC2-C-15035	HCC
150	25	90	CC2-C-15025	HCC
185	185	200	CC2-C-185185	HCC
185	150	200	CC2-C-185150	HCC
185	120	200	CC2-C-185120	HCC
185	95	150	CC2-C-18595	HCC
185	70	115	CC2-C-18570	HCC
185	50	115	CC2-C-18550	HCC
185	35	90	CC2-C-18535	HCC
185	25	90	CC2-C-18525	HCC
240	240	150x2	CC2-D-240240	HCD
240	185	200	CC2-D-240185	HCD
240	150	200	CC2-D-240150	HCD
240	120	200	CC2-D-240120	HCD
240	95	150	CC2-D-24095	HCD
240	70	115	CC2-C-24070	HCC
240	50	90	CC2-C-24050	HCC
240	35	90	CC2-C-24035	HCC
240	25	90	CC2-C-24025	HCC
300	300	200x2	CC2-D-300300	HCD
300	240	200x2	CC2-D-300240	HCD
300	185	250	CC2-D-300185	HCD
300	150	200	CC2-D-300150	HCD
300	120	150	CC2-D-300120	HCD
300	95	150	CC2-D-30095	HCD
300	70	150	CC2-D-30070	HCD
300	50	150	CC2-D-30050	HCD
300	35	150	CC2-D-30035	HCD
300	25	150	CC2-D-30025	HCD

Conductor Size		Metal Powder (g)	Graphite Mould Type	Handle Clamp Type
A _{mm²}	B _{mm²}			
10	10	32	CC4-N-1010	HCN
16	16	45	CC4-N-1616	HCN
25	25	45	CC4-N-2525	HCN
35	35	65	CC4-N-3535	HCN
35	25	65	CC4-N-3525	HCN
50	50	90	CC4-N-5050	HCN
50	35	90	CC4-N-5035	HCN
50	25	90	CC4-N-5025	HCN
70	70	115	CC4-N-7070	HCN
70	50	115	CC4-N-7050	HCN
70	35	115	CC4-N-7035	HCN
70	25	115	CC4-N-7025	HCN
95	95	150	CC4-C-9595	HCC
95	70	150	CC4-C-9570	HCC
95	50	115	CC4-C-9550	HCC
95	35	115	CC4-C-9535	HCC
95	25	115	CC4-C-9525	HCC
120	120	200	CC4-C-120120	HCC
120	95	200	CC4-C-12095	HCC
120	70	150	CC4-C-12070	HCC
120	50	150	CC4-C-12050	HCC
120	35	115	CC4-C-12035	HCC
120	25	115	CC4-C-12025	HCC
150	150	250	CC4-C-150150	HCC
150	120	250	CC4-C-150120	HCC
150	95	200	CC4-C-15095	HCC
150	70	150	CC4-C-15070	HCC
150	50	150	CC4-C-15050	HCC
150	35	115	CC4-C-15035	HCC
150	25	115	CC4-C-15025	HCC
185	185	150x2	CC4-D-185185	HCD
185	150	250	CC4-D-185150	HCD
185	120	250	CC4-C-185120	HCC
185	95	200	CC4-C-18595	HCC
185	70	200	CC4-C-18570	HCC
185	50	200	CC4-C-18550	HCC
185	35	150	CC4-C-18535	HCC
185	25	150	CC4-C-18525	HCC
240	240	250x2	CC4-D-240240	HCD
240	185	200x2	CC4-D-240185	HCD
240	150	200x2	CC4-D-240150	HCD
240	120	150x2	CC4-D-240120	HCD
240	95	150x2	CC4-D-24095	HCD
240	70	250	CC4-C-24070	HCC
240	50	250	CC4-C-24050	HCC
300	300	200x3	CC4-D-300300	HCD
300	240	200x3	CC4-D-300240	HCD
300	185	250x2	CC4-D-300185	HCD
300	150	250x2	CC4-D-300150	HCD
300	120	200x2	CC4-D-300120	HCD
300	95	200x2	CC4-D-30095	HCD

CC4

Cable to Cable

Horizontal to horizontal cable cross

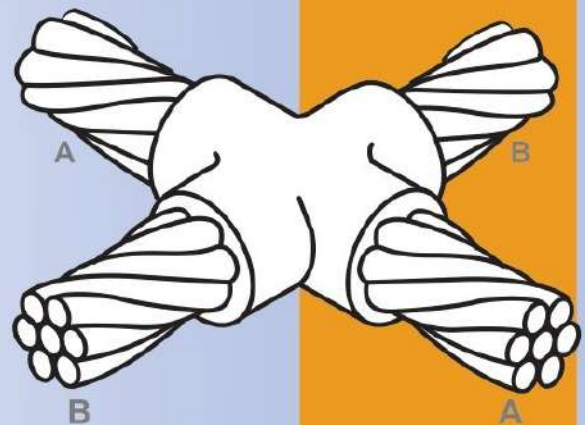

Tools Request :



CC6

Cable to Cable
Horizontal parallel
cable tap

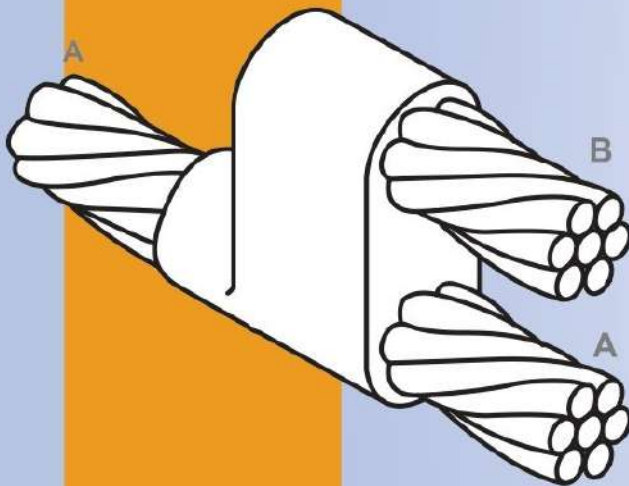

Conductor Size		Metal Powder (g)	Graphite Mould Type	Handle Clamp Type
A mm ²	B mm ²			
10	10	32	CC6-N-1010	HCN
16	16	32	CC6-N-1616	HCN
25	25	45	CC6-N-2525	HCN
35	35	65	CC6-N-3535	HCN
35	25	65	CC6-N-3525	HCN
50	50	90	CC6-N-5050	HCN
50	35	90	CC6-N-5035	HCN
50	25	65	CC6-N-5025	HCN
70	70	115	CC6-N-7070	HCN
70	50	115	CC6-N-7050	HCN
70	35	90	CC6-N-7035	HCN
70	25	90	CC6-N-7025	HCN
95	95	150	CC6-C-9595	HCC
95	70	150	CC6-C-9570	HCC
95	50	115	CC6-N-9550	HCN
95	35	115	CC6-N-9535	HCN
120	120	200	CC6-C-120120	HCC
120	95	200	CC6-C-12095	HCC
120	70	150	CC6-C-12070	HCC
120	50	150	CC6-C-12050	HCC
150	150	150X2	CC6-C-150150	HCC
150	120	250	CC6-C-150120	HCC
150	95	200	CC6-C-15095	HCC
150	70	150	CC6-C-15070	HCC
185	185	150X2	CC6-C-185185	HCC
185	150	150X2	CC6-C-185150	HCC
185	120	250	CC6-C-185120	HCC
185	95	200	CC6-C-18595	HCC
240	240	200X2	CC6-D-240240	HCD
240	185	150X2	CC6-D-240185	HCD
240	150	150X2	CC6-D-240150	HCD
240	120	250	CC6-D-240120	HCD
300	300	250x2	CC6-D-300300	HCD
300	240	250x2	CC6-D-300240	HCD
300	185	200x2	CC6-D-300185	HCD
300	150	150x2	CC6-D-300150	HCD

Tools Request :



Mould



Mould brush



Handle clamp



Scraper



Metal powder



Steel disk



Flint igniter



Bus bar brush

Conductor Size		Metal Powder (g)	Graphite Mould Type	Handle Clamp Type
A mm ²	B mm ²			
10	10	32	CC7-N-1010	HCN
16	16	32	CC7-N-1616	HCN
25	25	45	CC7-N-2525	HCN
35	35	65	CC7-N-3535	HCN
35	25	65	CC7-N-3525	HCN
50	50	90	CC7-N-5050	HCN
50	35	90	CC7-N-5035	HCN
50	25	65	CC7-N-5025	HCN
70	70	115	CC7-N-7070	HCN
70	50	115	CC7-N-7050	HCN
70	35	90	CC7-N-7035	HCN
70	25	90	CC7-N-7025	HCN
95	95	150	CC7-C-9595	HCC
95	70	150	CC7-C-9570	HCC
95	50	115	CC7-N-9550	HCN
95	35	115	CC7-N-9535	HCN
120	120	200	CC7-C-120120	HCC
120	95	200	CC7-C-12095	HCC
120	70	150	CC7-C-12070	HCC
120	50	150	CC1-C-12050	HCC
150	150	150x2	CC7-C-150150	HCC
150	120	250	CC7-C-150120	HCC
150	95	200	CC7-C-15095	HCC
150	70	150	CC7-C-15070	HCC
185	185	150x2	CC7-C-185185	HCC
185	150	150x2	CC7-C-185150	HCC
185	120	250	CC7-C-185120	HCC
185	95	200	CC7-C-18595	HCC
240	240	200x2	CC7-D-240240	HCD
240	185	150x2	CC7-D-240185	HCD
240	150	150x2	CC7-D-240150	HCD
240	120	250	CC7-D-240120	HCD
300	300	250x2	CC7-D-300300	HCD
300	240	250x2	CC7-D-300240	HCD
300	185	200x2	CC7-D-300185	HCD
300	150	150x2	CC7-D-300150	HCD

CC7

Cable to Cable
Horizontal parallel
thru cables

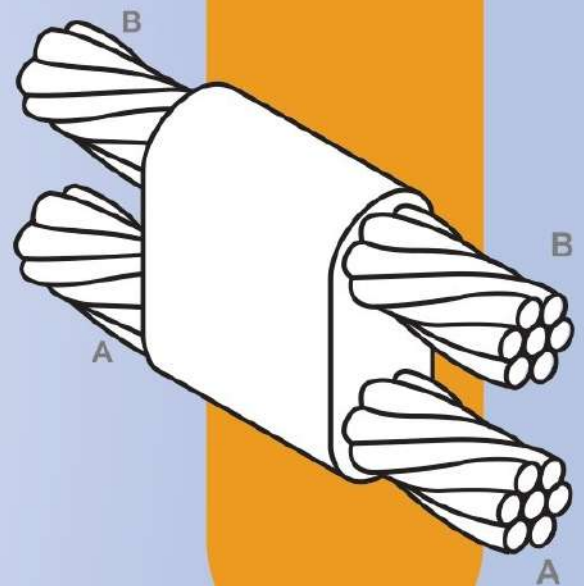

Tools Request :



CC11

Cable to Cable
Horizontal to
horizontal cable cross

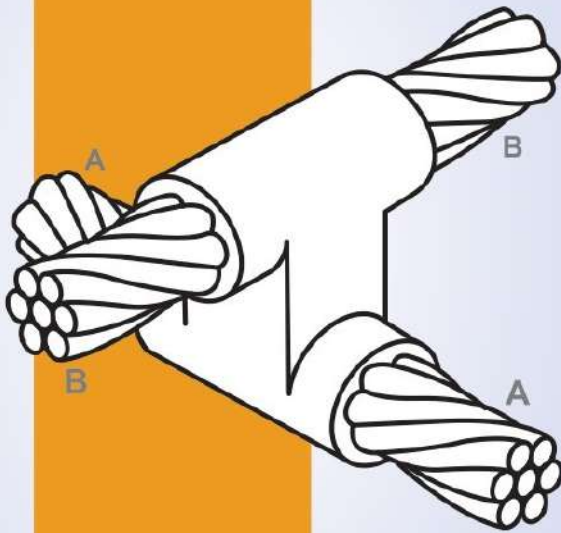

Conductor Size		Metal Powder (g)	Graphite Mould Type	Handle Clamp Type
A mm ²	B mm ²			
25	25	65	CC11-E-2525	HCC
35	35	90	CC11-E-3535	HCC
	25	90	CC11-E-3525	HCC
50	50	150	CC11-E-5050	HCC
	35	115	CC11-E-5035	HCC
	25	115	CC11-E-5025	HCC
70	70	200	CC11-E-7070	HCC
	50	200	CC11-E-7050	HCC
	35	150	CC11-E-7035	HCC
95	95	250	CC11-E-9595	HCC
	70	200	CC11-E-9570	HCC
	50	200	CC11-E-9550	HCC
	35	150	CC11-E-9535	HCC
100	100	250	CC4-E-100100	HCC
120	120	2 x 150	CC11-E-120120	HCC
	95	2 x 150	CC11-E-12095	HCC
	70	250	CC11-E-12070	HCC
	50	250	CC11-E-12050	HCC
	35	200	CC11-E-12035	HCC
	150	150	2 x 200	CC11-D-150150
120		2 x 200	CC11-D-150120	HCD
95		2 x 150	CC11-E-15095	HCC
70		250	CC11-E-15070	HCC
50		250	CC11-E-15050	HCC
35		150	CC11-E-15035	HCC
185	185	2 x 250	CC11-D-185185	HCD
	150	2 x 250	CC11-D-185150	HCD
	120	2 x 250	CC11-D-185120	HCD
	95	2 x 200	CC11-D-18595	HCD
	70	2 x 150	CC11-D-18570	HCD
	50	250	CC11-E-18550	HCC
240	35	200	CC11-E-18535	HCC
	240	3 x 200	CC11-D-240240	HCD
	185	3 x 200	CC11-D-240185	HCD
	150	3 x 200	CC11-D-240150	HCD
	120	3 x 200	CC11-D-240120	HCD
	95	2 x 250	CC11-D-24095	HCD
300	70	2 x 250	CC11-D-24070	HCD
	50	2 x 200	CC11-D-24050	HCD
	300	3 x 250	CC11-D-300300	HCD
	240	3 x 250	CC11-D-300240	HCD
	185	3 x 200	CC11-D-300185	HCD
	150	3 x 200	CC11-D-300150	HCD
120	2 x 250	CC11-D-300120	HCD	
	95	2 x 250	CC11-D-30095	HCD

Tools Request :



CC13

Cable to Cable
Horizontal parallel
cable tap (side by side)

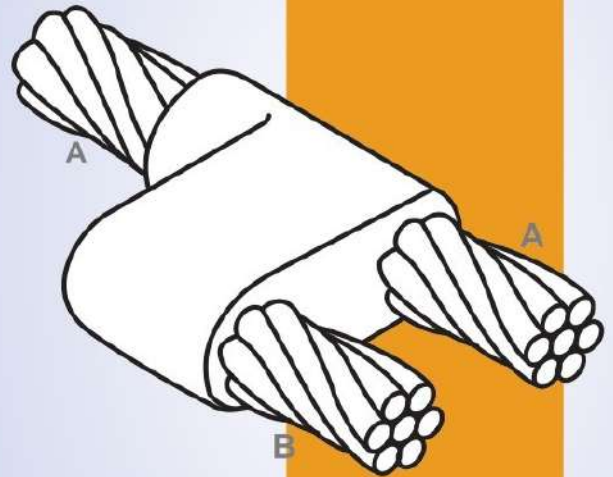

Conductor Size		Metal Powder (g)	Graphite Mould Type	Handle Clamp Type
A _{mm²}	B _{mm²}			
10	10	45	CC13-N-1010	HCN
16	16	45	CC13-N-1616	HCN
25	25	45	CC13-N-2525	HCN
35	35	65	CC13-N-3535	HCN
	25	65	CC13-N-3525	HCN
50	50	90	CC13-N-5050	HCN
	35	65	CC13-N-5035	HCN
	25	65	CC13-N-5025	HCN
70	70	115	CC13-N-7070	HCN
	50	115	CC13-N-7050	HCN
	35	90	CC13-N-7035	HCN
	25	90	CC13-N-7025	HCN
95	95	150	CC13-C-9595	HCC
	70	115	CC13-C-9570	HCC
	50	115	CC13-C-9550	HCC
	35	115	CC13-C-9535	HCC
120	120	200	CC13-C-120120	HCC
	95	200	CC13-C-12095	HCC
	70	150	CC13-C-12070	HCC
	50	115	CC13-C-12050	HCC
150	150	250	CC13-C-150150	HCC
	120	250	CC13-C-150120	HCC
	95	200	CC13-C-15095	HCC
	70	150	CC13-C-15070	HCC
	50	150	CC13-C-15050	HCC
185	185	2 x 150	CC13-D-185185	HCD
	150	2 x 150	CC13-D-185150	HCD
	120	250	CC13-C-185120	HCC
	95	200	CC13-C-18595	HCC
	70	200	CC13-C-18570	HCC
240	240	2 x 200	CC13-D-240240	HCD
	185	2 x 150	CC13-D-240185	HCD
	150	2 x 150	CC13-D-240150	HCD
	120	250	CC13-C-240120	HCC
300	300	2 x 250	CC13-D-300300	HCD
	240	2 x 250	CC13-D-300240	HCD
	185	2 x 200	CC13-D-300185	HCD
	150	2 x 150	CC13-D-300150	HCD

Tools Request :



CC14

Cable to Cable
Horizontal parallel
thru cable tap (side by side)

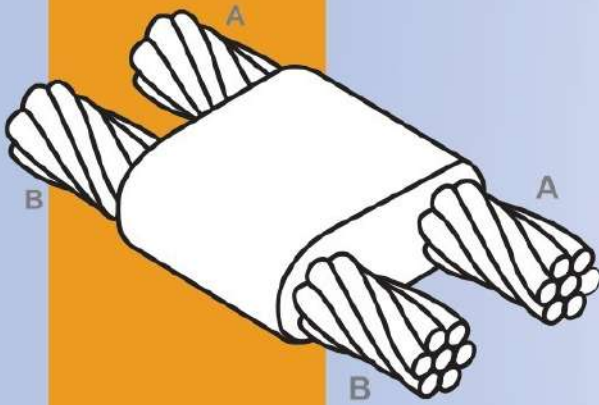

Conductor Size		Metal Powder (g)	Graphite Mould Type	Handle Clamp Type
A mm ²	B mm ²			
10	10	45	CC14-N-1010	HCN
16	16	45	CC14-N-1616	HCN
25	25	45	CC14-N-2525	HCN
35	35	65	CC14-N-3535	HCN
35	25	65	CC14-N-3525	HCN
50	50	90	CC14-N-5050	HCN
50	35	65	CC14-N-5035	HCN
50	25	65	CC14-N-5025	HCN
70	70	115	CC14-N-7070	HCN
70	50	115	CC14-N-7050	HCN
70	35	90	CC14-N-7035	HCN
70	25	90	CC14-N-7025	HCN
95	95	150	CC14-C-9595	HCC
95	70	150	CC14-C-9570	HCC
95	50	150	CC14-C-9550	HCC
95	35	115	CC14-C-9535	HCC
120	120	200	CC14-C-120120	HCC
120	95	200	CC14-C-12095	HCC
120	70	150	CC14-C-12070	HCC
120	50	150	CC14-C-12050	HCC
150	150	150x2	CC14-C-150150	HCC
150	120	250	CC14-C-150120	HCC
150	95	200	CC14-C-15095	HCC
150	70	150	CC14-C-15070	HCC
150	50	150	CC14-C-15050	HCC
150	35	115	CC14-C-15035	HCC
150	25	115	CC14-C-15025	HCC
185	185	150x2	CC14-D-185185	HCD
185	150	150x2	CC14-D-185150	HCD
185	120	250	CC14-C-185120	HCC
185	95	200	CC14-C-18595	HCC
185	70	200	CC14-C-18570	HCC
185	50	150	CC14-C-18550	HCC
185	35	150	CC14-C-18535	HCC
185	25	150	CC14-C-18525	HCC
240	240	200x2	CC14-D-240240	HCD
240	185	150x2	CC14-D-240185	HCD
240	150	150x2	CC14-D-240150	HCD
240	120	250	CC14-D-240120	HCD
240	95	250	CC14-D-24095	HCD
240	70	200	CC14-C-24070	HCC
240	50	250	CC14-C-24050	HCC
300	300	250x2	CC14-D-300300	HCD
300	240	250x2	CC14-D-300240	HCD
300	185	200x2	CC14-D-300185	HCD
300	150	150x2	CC14-D-300150	HCD
300	120	150x2	CC14-D-300120	HCD
300	95	250	CC14-D-30095	HCD

Tools Request :



CS1

Cable to Steel
Horizontal cable
to horizontal steel surface
(off surface)

Conductor Size	Metal Powder	Graphite Mould Type	Handle Clamp Type
A _{mm²}	(g)	Type	Type
10	45	CS1-A-10	HCA
16	45	CS1-A-16	HCA
25	45	CS1-A-25	HCA
35	65	CS1-A-35	HCA
50	65	CS1-A-50	HCA
70	90	CS1-A-70	HCA
95	90	CS1-A-95	HCA
120	115	CS1-C-120	HCC
150	150	CS1-C-150	HCC
165	200	CS1-C-165	HCC
240	200	CS1-C-240	HCC
300	250	CS1-C-300	HCC

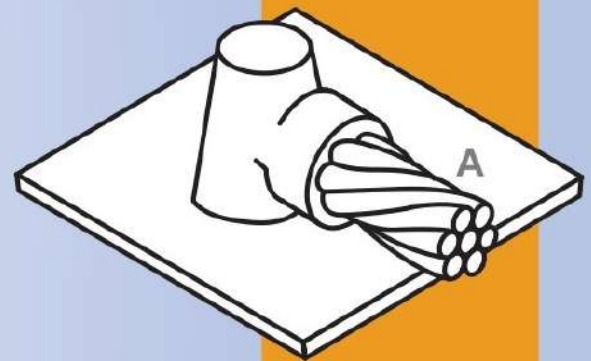

Tools Request :



Mould



Mould brush



Handle clamp



Scraper



Metal powder



Steel disk



Flint igniter



Bus bar brush

CS2

Cable to Steel
Horizontal thru cable
to horizontal steel surface

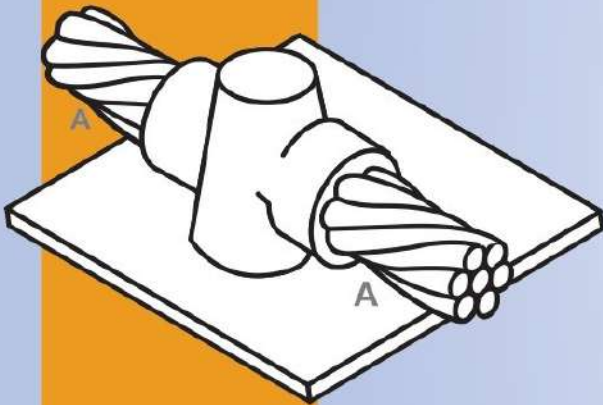

Conductor Size	Metal Powder (g)	Graphite Mould Type	Handle Clamp Type
A _{mm²}			
10	45	CS2-A-10	HCA
16	45	CS2-A-16	HCA
25	45	CS2-A-25	HCA
35	65	CS2-A-35	HCA
50	65	CS2-A-50	HCA
70	90	CS2-C-70	HCC
95	90	CS2-C-95	HCC
120	115	CS2-C-120	HCC
150	150	CS2-C-150	HCC
185	250	CS2-C-185	HCC
240	300	CS2-D-240	HCD
300	400	CS2-D-300	HCD

Tools Request :



Mould



Mould brush



Handle clamp



Scraper



Metal powder



Steel disk



Flint igniter



Bus bar brush

CS3

Cable to Steel
Angular cable drop
to vertical steel surface

Conductor Size	Metal Powder (g)	Graphite Mould Type	Handle Clamp Type
A mm ²			
10	45	CS3-E-10	HCC
16	45	CS3-E-16	HCC
25	45	CS3-E-25	HCC
35	65	CS3-E-35	HCC
50	90	CS3-E-50	HCC
70	90	CS3-E-70	HCC
95	115	CS3-E-95	HCC
120	115	CS3-E-120	HCC
150	150	CS3-E-150	HCC
185	200	CS3-E-185	HCC
240	250	CS3-D-240	HCD
300	250	CS3-D-300	HCD

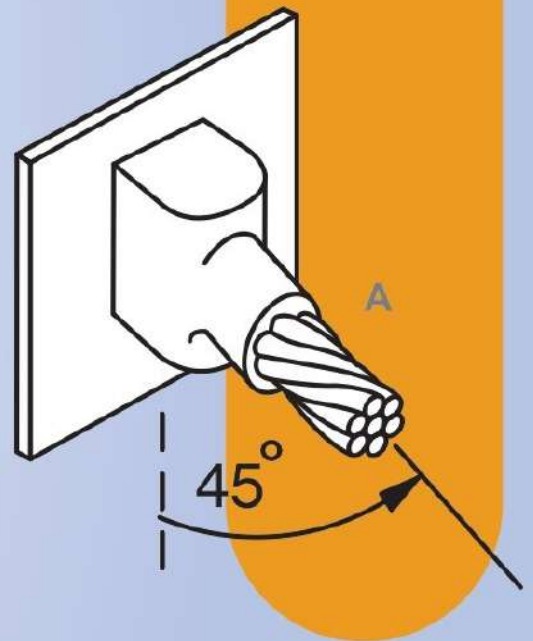

Tools Request :



CS4

Cable to Steel
Vertical thru cable
to vertical steel surface
(off surface)

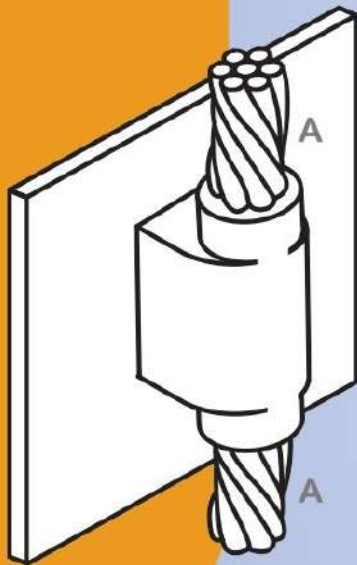

Conductor Size A mm ²	Metal Powder (g)	Graphite Mould Type	Handle Clamp Type
25	90	CS4-E-25	HCC
35	115	CS4-E-35	HCC
50	200	CS4-E-50	HCC
70	200	CS4-E-70	HCC
95	250	CS4-E-95	HCC
120	250	CS4-E-120	HCC
150	250	CS4-E-150	HCC

Tools Request :



Mould



Mould brush



Handle clamp



Scraper



Metal powder



Steel disk



Flint igniter



Bus bar brush

CS6

Cable to Steel
Horizontal thru cable
to vertical steel surface
(off surface)

Conductor Size	Metal Powder	Graphite Mould	Handle Clamp
A _{mm²}	(g)	Type	Type
25	65	CS6-E-25	HCC
35	65	CS6-E-35	HCC
50	115	CS6-E-50	HCC
70	115	CS6-E-70	HCC
95	150	CS6-E-95	HCC
120	150	CS6-E-120	HCC

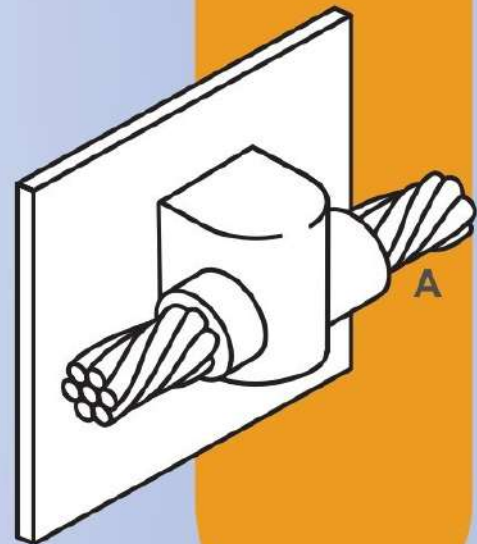

Tools Request :



Mould



Mould brush



Handle clamp



Scraper



Metal powder



Steel disk



Flint igniter



Bus bar brush

CS7

Cable to Steel
Overhead vertical tap cable
to vertical steel surface
(on surface)

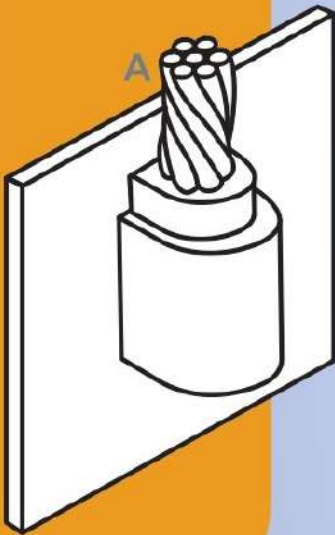

Conductor Size	Metal Powder	Graphite Mould	Handle Clamp
A _{mm²}	(g)	Type	Type
10	65	CS7-E-10	HCC
16	65	CS7-E-16	HCC
25	115	CS7-E-25	HCC
35	115	CS7-E-35	HCC
50	150	CS7-E-50	HCC
70	150	CS7-E-70	HCC
95	200	CS7-E-95	HCC
120	200	CS7-E-120	HCC
150	250	CS7-E-150	HCC
185	300	CS7-E-185	HCC
240	400	CS7-D-240	HCD
300	400	CS7-D-300	HCD

Tools Request :



Mould



Mould brush



Handle clamp



Scraper



Metal powder



Steel disk



Flint igniter



Bus bar brush

CS8

Cable to Steel
Horizontal cable
to horizontal steel surface
(on surface)

Conductor Size	Metal Powder	Graphite Mold	Handle Clamp
A _{mm²}	(g)	Type	Type
10	45	CS8-A-10	HCA
16	45	CS8-A-16	HCA
25	45	CS8-A-25	HCA
35	65	CS8-A-35	HCA
50	90	CS8-A-50	HCA
70	90	CS8-A-70	HCA
95	115	CS8-A-95	HCA
120	115	CS8-C-120	HCC
150	150	CS8-C-150	HCC
185	200	CS8-C-185	HCC
240	250	CS8-C-240	HCC
300	250	CS8-C-300	HCC



Tools Request :



Mould



Mould brush



Handle clamp



Scraper



Metal powder



Steel disk



Flint igniter



Bus bar brush

CS9

Cable to Steel
Horizontal thru cable
to horizontal steel surface
(on surface)

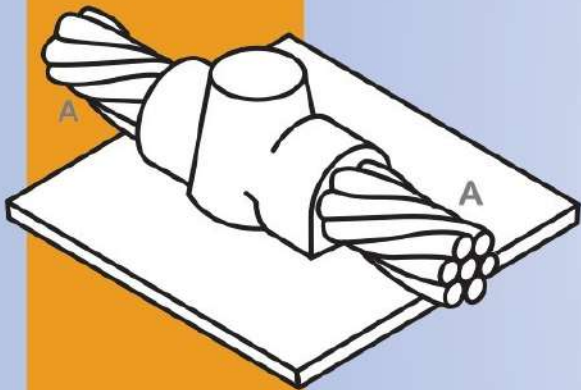

Conductor Size	Metal Powder	Graphite Mould Type	Handle Clamp Type
A, mm ²	(g)		
10	45	CS9-C-10	HCC
16	45	CS9-C-16	HCC
25	65	CS9-C-25	HCC
35	65	CS9-C-35	HCC
50	90	CS9-C-50	HCC
70	115	CS9-C-70	HCC
95	115	CS9-C-95	HCC
120	150	CS9-C-120	HCC
150	200	CS9-C-150	HCC
185	250	CS9-C-185	HCC
240	150x2	CS9-D-240	HCD
300	200x2	CS9-D-300	HCD

Tools Request :



Mould



Mould brush



Handle clamp



Scraper



Metal powder



Steel disk



Flint igniter



Bus bar brush

CS23

Cable to Steel
Vertical cable down
to vertical steel surface
(off surface)

Conductor Size A mm ²	Metal Powder (g)	Graphite Mould Type	Handle Clamp Type
25	45	CS23-E-25	HCC
35	45	CS23-E-35	HCC
50	90	CS23-E-50	HCC
70	90	CS23-E-70	HCC
95	115	CS23-E-95	HCC
120	115	CS23-E-120	HCC



Tools Request :



Mould



Mould brush



Handle clamp



Scraper

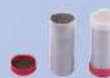

Metal powder



Steel disk



Flint igniter



Bus bar brush

BB1

Bus Bar to Bus Bar
Horizontal bus bar end to end
(vertical flat side)

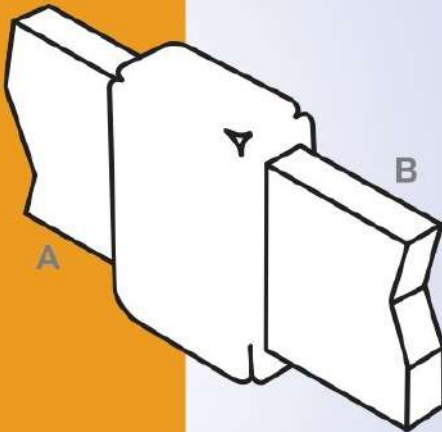

Conductor Size		Metal Powder (g)	Graphite Mould Type	Handle Clamp Type
A mm x mm	B mm x mm			
20x2		45	BB1-N-202	HCN
20x3		45	BB1-N-203	HCN
25x3		65	BB1-N-253	HCN
25x4		90	BB1-N-254	HCN
25x6		115	BB1C-256	HCC
30x2		65	BB1-N-302	HCN
30x3		90	BB1-N-303	HCN
30x4		115	BB1-C-304	HCC
30x5		115	BB1-C-305	HCC
31x3		90	BB1-C-313	HCC
31x6		115	BB1-C-316	HCC
38x3		150	BB1-C-383	HCC
38x5		150	BB1-C-385	HCC
38x6		200	BB1-C-386	HCC
40x3		115	BB1-C-403	HCC
40x4		150	BB1-C-404	HCC
40x5		150	BB1-C-405	HCC
40x6		200	BB1-C-406	HCC
50x3		115	BB1-C-503	HCC
50x4		115	BB1-C-504	HCC
50x5		200	BB1-C-505	HCC
50x6		250	BB1-C-506	HCC
50x8		150x2	BB1-D-508	HCD
60x6		250	BB1-C-606	HCC
60x8		200x2	BB1-D-608	HCD
60x10		250x2	BB1-D-6010	HCD
80x6		200x2	BB1-D-806	HCD
80x8		250x2	BB1-D-808	HCD
80x10		200x3	BB1-D-8010	HCD

Tools Request :



Mould



Mould brush



Handle clamp



Scraper



Metal powder



Steel disk



Flint igniter



Bus bar brush

Conductor Size		Metal Powder (g)	Graphite Mould Type	Handle Clamp Type
A mm x mm	B mm x mm			
20 x 2	20 x 2	45	BB2-C-202	HCC
20 x 3	20 x 3	45	BB2-C-203	HCC
20 x 4	20 x 4	65	BB2-C-204	HCC
20 x 5	20 x 5	90	BB2-C-205	HCC
25 x 2	25 x 2	45	BB2-C-252	HCC
25 x 3	25 x 3	65	BB2-C-253	HCC
25 x 4	25 x 4	90	BB2-C-254	HCC
25 x 5	25 x 5	90	BB2-C-255	HCC
25 x 6	25 x 6	115	BB2-C-256	HCC
25 x 8	25 x 8	150	BB2-C-258	HCC
25 x 12	25 x 12	250	BB2-C-2512	HCC
30 x 2	30 x 2	65	BB2-C-302	HCC
30 x 3	30 x 3	65	BB2-C-303	HCC
30 x 4	30 x 4	90	BB2-C-304	HCC
30 x 5	30 x 5	115	BB2-C-305	HCC
30 x 6	30 x 6	150	BB2-C-306	HCC
31 x 3	31 x 3	65	BB2-C-313	HCC
31 x 6	31 x 6	150	BB2-C-316	HCC
38 x 3	38 x 3	115	BB2-C-383	HCC
38 x 5	38 x 5	115	BB2-C-385	HCC
38 x 6	38 x 6	200	BB2-C-386	HCC
38 x 8	38 x 8	250	BB2-C-388	HCC
40 x 3	40 x 3	90	BB2-C-403	HCC
40 x 4	40 x 4	115	BB2-C-404	HCC
40 x 5	40 x 5	150	BB2-C-405	HCC
40 x 6	40 x 6	200	BB2-C-406	HCC
50 x 3	50 x 3	90	BB2-C-503	HCC
50 x 4	50 x 4	115	BB2-C-504	HCC
50 x 5	50 x 5	200	BB2-C-505	HCC
50 x 6	50 x 6	250	BB2-C-506	HCC
50 x 8	50 x 8	2 x 150	BB2-D-508	HCD
50 x 10	50 x 10	2 x 200	BB2-D-5010	HCD
60 x 6	60 x 6	2 x 150	BB2-D-606	HCD
60 x 8	60 x 8	2 x 200	BB2-D-608	HCD
60 x 10	60 x 10	2 x 250	BB2-D-6010	HCD
80 x 6	80 x 6	2 x 150	BB2-D-806	HCD
80 x 8	80 x 8	2 x 200	BB2-D-808	HCD
80 x 10	80 x 10	2 x 250	BB2-D-8010	HCD

BB2

Bus Bar to Bus Bar
Horizontal bus bar tap
to vertical bus bar down

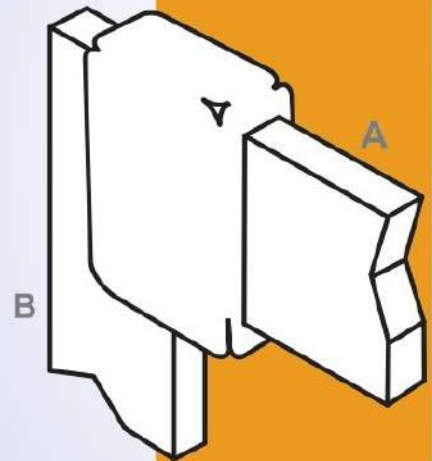

Tools Request :



BB3

Bus Bar to Bus Bar
Vertical bus bar drop tap
to horizontal bus run

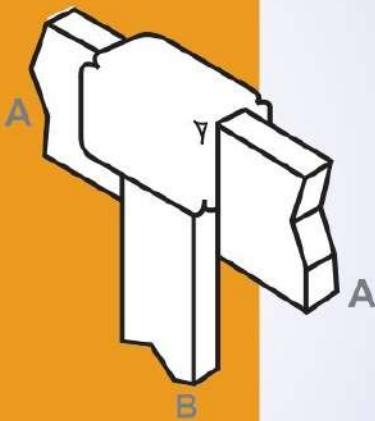

Conductor Size		Metal Powder (g)	Graphite Mould Type	Handle Clamp Type
A <small>(mm x mm)</small>	B <small>(mm x mm)</small>			
20x2	20x2	45	BB3-C-202202	HCC
20x3	20x3	65	BB3-C-203203	HCC
25x3	25x3	65	BB3-C-253253	HCC
25x4	25x4	90	BB3-C-254254	HCC
25x6	25x6	150	BB3-C-256256	HCC
30x2	30x2	65	BB3-C-302302	HCC
30x3	30x3	90	BB3-C-303303	HCC
30x4	30x4	115	BB3-C-304304	HCC
30x5	30x5	150	BB3-C-305305	HCC
31x3	31x3	115	BB3-C-313313	HCC
31x6	31x6	200	BB3-C-316316	HCC
38x3	38x3	115	BB3-C-383383	HCC
38x5	38x5	150	BB3-C-385385	HCC
38x6	38x6	200	BB3-C-386386	HCC
40x3	40x3	115	BB3-C-403403	HCC
40x4	40x4	150	BB3-C-404404	HCC
40x5	40x5	150	BB3-C-405405	HCC
40x6	40x6	200	BB3-C-406406	HCC
50x3	50x3	150	BB3-C-503503	HCC
50x4	50x4	200	BB3-C-504504	HCC
50x5	50x5	200	BB3-D-505505	HCD
50x6	50x6	250	BB3-D-506506	HCD
50x8	50x8	150x2	BB3-D-508508	HCD
60x6	60x6	150x2	BB3-D-606606	HCD
60x8	60x8	200x2	BB3-D-608608	HCD
60x10	60x10	250x2	BB3-D-60106010	HCD
80x6	80x6	200x2	BB3-D-806806	HCD
80x8	80x8	250x2	BB3-D-808808	HCD
80x10	80x10	200x3	BB3-D-80108010	HCD

Tools Request :



Conductor Size		Metal Powder (g)	Graphite Mould Type	Handle Clamp Type
A mm x mm	B mm x mm			
20 x 2	20 x 2	45	BB7-N-202	HCN
20 x 3	20 x 3	45	BB7-N-203	HCN
20 x 4	20 x 4	65	BB7-N-204	HCN
20 x 5	20 x 5	90	BB7-N-205	HCN
25 x 2	25 x 2	45	BB7-N-252	HCN
25 x 3	25 x 3	65	BB7-N-253	HCN
25 x 4	25 x 4	90	BB7-N-254	HCN
25 x 5	25 x 5	90	BB7-N-255	HCN
25 x 6	25 x 6	115	BB7-C-256	HCC
25 x 8	25 x 8	150	BB7-C-258	HCC
25 x 12	25 x 12	200	BB7-C-2512	HCC
30 x 2	30 x 2	65	BB7-N-302	HCN
30 x 3	30 x 3	65	BB7-N-303	HCN
30 x 4	30 x 4	90	BB7-N-304	HCN
30 x 5	30 x 5	115	BB7-C-305	HCC
30 x 6	30 x 6	150	BB7-C-306	HCC
31 x 3	31 x 3	65	BB7-C-313	HCC
31 x 6	31 x 6	150	BB7-C-316	HCC
38 x 3	38 x 3	90	BB7-C-383	HCC
38 x 5	38 x 5	150	BB7-C-385	HCC
38 x 6	38 x 6	200	BB7-C-386	HCC
38 x 8	38 x 8	250	BB7-C-388	HCC
40 x 3	40 x 3	90	BB7-C-403	HCC
40 x 4	40 x 4	115	BB7-C-404	HCC
40 x 5	40 x 5	150	BB7-C-405	HCC
40 x 6	40 x 6	200	BB7-C-406	HCC
50 x 3	50 x 3	150	BB7-D-503	HCD
50 x 4	50 x 4	200	BB7-D-504	HCD
50 x 5	50 x 5	200	BB7-D-505	HCD
50 x 6	50 x 6	250	BB7-D-506	HCD
50 x 8	50 x 8	2 x 150	BB7-D-508	HCD
50 x 10	50 x 10	2 x 200	BB7-D-5010	HCD
60 x 6	60 x 6	2 x 150	BB7-D-606	HCD
60 x 8	60 x 8	2 x 200	BB7-D-608	HCD
60 x 10	60 x 10	2 x 250	BB7-D-6010	HCD
80 x 6	80 x 6	2 x 200	BB7-D-806	HCD
80 x 8	80 x 8	2 x 250	BB7-D-808	HCD
80 x 10	80 x 10	3 x 200	BB7-D-8010	HCD

BB7

Bus Bar to Bus Bar Horizontal flat bus bar end to end

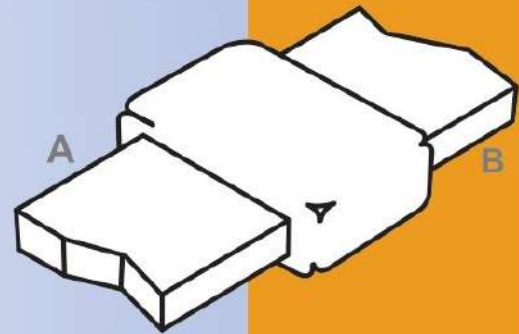

Tools Request :



Mould



Mould brush



Handle clamp



Scraper



Metal powder



Steel disk



Flint igniter



Bus bar brush

BB40

Bus Bar to Bus Bar
Horizontal flat bus bar cross

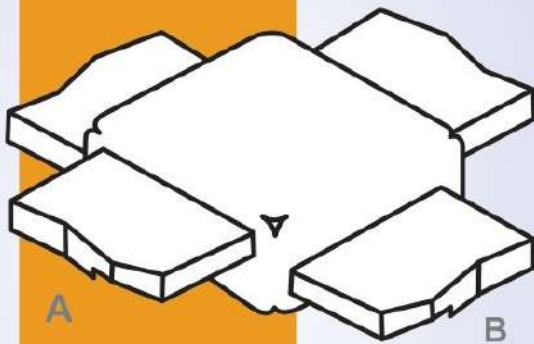

Conductor Size		Metal Powder (g)	Graphite Mould Type	Handle Clamp Type
A mm x mm	B mm x mm			
20 x 2	20 x 2	65	BB40-C-202202	HCC
20 x 3	20 x 3	90	BB40-C-203203	HCC
20 x 5	20 x 5	115	BB40-C-205205	HCC
25 x 2	25 x 2	90	BB40-C-252252	HCC
25 x 3	25 x 3	90	BB40-C-253253	HCC
25 x 4	25 x 4	115	BB40-C-254254	HCC
25 x 5	25 x 5	150	BB40-C-255255	HCC
25 x 6	25 x 6	150	BB40-C-256256	HCC
25 x 8	25 x 8	200	BB40-C-258258	HCC
25 x 12	25 x 12	200	BB40-C-25122512	HCC
30 x 2	30 x 2	150	BB40-C-302302	HCC
30 x 3	30 x 3	200	BB40-C-303303	HCC
30 x 4	30 x 4	200	BB40-C-304304	HCC
30 x 5	30 x 5	250	BB40-C-305305	HCC
30 x 6	30 x 6	250	BB40-C-306306	HCC
31 x 3	31 x 3	200	BB40-C-313313	HCC
31 x 6	31 x 6	250	BB40-C-316316	HCC
38 x 3	38 x 3	250	BB40-D-383383	HCD
38 x 5	38 x 5	2 X 150	BB40-D-385385	HCD
38 x 6	38 x 6	2 X 150	BB40-D-386386	HCD
38 x 8	38 x 8	2 X 200	BB40-D-388388	HCD
40 x 3	40 x 3	2 X 200	BB40-D-403403	HCD
40 x 4	40 x 4	2 X 200	BB40-D-404404	HCD
40 x 5	40 x 5	2 X 200	BB40-D-405405	HCD
40 x 6	40 x 6	2 X 200	BB40-D-406406	HCD
50 x 3	50 x 3	2 X 250	BB40-D-503503	HCD
50 x 4	50 x 4	2 X 250	BB40-D-504504	HCD
50 x 5	50 x 5	2 X 250	BB40-D-505505	HCD
50 x 6	50 x 6	2 X 250	BB40-D-506506	HCD
50 x 8	50 x 8	3 X 250	BB40-D-508508	HCD
50 x 10	50 x 10	4 X 250	BB40-D-50105010	HCD
60 x 6	60 x 6	4 X 200	BB40-D-606606	HCD
60 x 8	60 x 8	4 X 250	BB40-D-608608	HCD
60 x 10	60 x 10	5 X 250	BB40-D-60106010	HCD

Tools Request :



Conductor Size		Metal Powder (g)	Graphite Mould Type	Handle Clamp Type
A mm x mm	B mm x mm			
20 x 2	20 x 2	65	BB41-C-202202	HCC
20 x 3	20 x 3	65	BB41-C-203203	HCC
20 x 4	20 x 4	90	BB41-C-204204	HCC
20 x 5	20 x 5	90	BB41-C-205205	HCC
25 x 2	25 x 2	65	BB41-C-252252	HCC
25 x 3	25 x 3	65	BB41-C-253253	HCC
25 x 4	25 x 4	90	BB41-C-254254	HCC
25 x 5	25 x 5	90	BB41-C-255255	HCC
25 x 6	25 x 6	115	BB41-C-256256	HCC
25 x 8	25 x 8	250	BB41-C-258258	HCC
25 x 12	25 x 12	250	BB41-C-25122512	HCC
30 x 2	30 x 2	90	BB41-C-302302	HCC
30 x 3	30 x 3	115	BB41-C-303303	HCC
30 x 4	30 x 4	115	BB41-C-304304	HCC
30 x 5	30 x 5	115	BB41-C-305305	HCC
30 x 6	30 x 6	200	BB41-C-306306	HCC
31 x 3	31 x 3	115	BB41-C-313313	HCC
31 x 6	31 x 6	115	BB41-C-316316	HCC
38 x 3	38 x 3	150	BB41-C-383383	HCC
38 x 5	38 x 5	150	BB41-C-385385	HCC
38 x 6	38 x 6	200	BB41-C-386386	HCC
38 x 8	38 x 8	250	BB41-C-388388	HCC
40 x 3	40 x 3	150	BB41-C-403403	HCC
40 x 4	40 x 4	200	BB41-C-404404	HCC
40 x 5	40 x 5	200	BB41-C-405405	HCC
40 x 6	40 x 6	200	BB41-C-406406	HCC
50 x 3	50 x 3	200	BB41-D-503503	HCD
50 x 4	50 x 4	200	BB41-D-504504	HCD
50 x 5	50 x 5	200	BB41-D-505505	HCD
50 x 6	50 x 6	200	BB41-D-506506	HCD
50 x 8	50 x 8	250	BB41-D-508508	HCD
50 x 10	50 x 10	2 x 150	BB41-D-50105010	HCD
60 x 6	60 x 6	200	BB41-D-606606	HCD
60 x 8	60 x 8	250	BB41-D-608608	HCD
60 x 10	60 x 10	2 x 150	BB41-D-60106010	HCD
80 x 6	80 x 6	200	BB41-D-806806	HCD
80 x 8	80 x 8	250	BB41-D-808808	HCD
80 x 10	80 x 10	2 x 150	BB41-D-80108010	HCD

BB41

Bus Bar to Bus Bar
Horizontal flat
bus bar cross

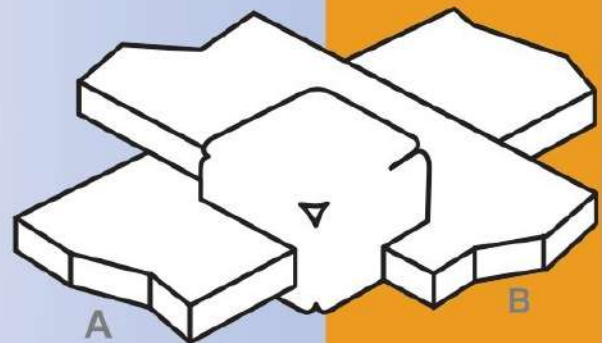

Tools Request :



Mould



Mould brush



Handle clamp



Scraper



Metal powder



Steel disk



Flint igniter



Bus bar brush

CX7

Cable to Rail Bond to base of rail (foot)

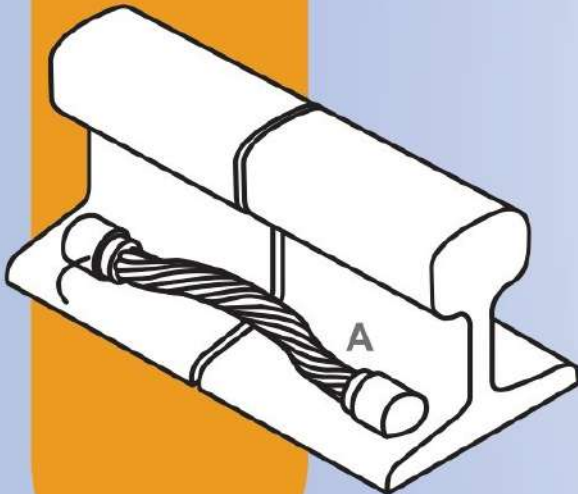

Conductor A _{mm²}	Metal Powder (g)	Graphite Mould Type	Handle Clamp Type
50	45	CX7L- E-50	HCC
50	45	CX7R- E-50	HCC
70	45	CX7L- E-70	HCC
70	45	CX7R- E-70	HCC
120	65	CX7L- E -120	HCC
120	65	CX7R- E -120	HCC
150	90	CX7L- E -150	HCC
150	90	CX7R- E -150	HCC

Tools Request :



Mould



Mould brush



Handle clamp



Scraper

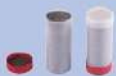

Metal powder



Steel disk



Flint igniter



Bus bar brush

CB4

Cable to Bus Bar Horizontal cable tap to horizontal bus

Conductor Size		Metal Powder (g)	Graphite Mould Type	Handle Clamp Type
A mm ²	B mm/mm			
16	20x2	45	CB4-N-16202	HCN
	20x3	65	CB4-N-16202	HCN
	25x4	65	CB4-N-16202	HCN
25	20x2	65	CB4-N-16202	HCN
	20x3	65	CB4-N-16202	HCN
	25x4	65	CB4-N-16202	HCN
35	20x2	65	CB4-N-16202	HCN
	20x3	90	CB4-N-35203	HCN
	25x3	90	CB4-N-35203	HCN
50	25x3	90	CB4-N-50253	HCN
	25x4	115	CB4-N-50254	HCN
	25x5	115	CB4-N-50255	HCN
70	25x3	115	CB4-N-70253	HCN
	25x4	115	CB4-N-70254	HCN
	25x5	150	CB4-C-70255	HCC
95	25x3	115	CB4-C-95253	HCC
	25x5	150	CB4-C-95255	HCC
	25x6	150	CB4-C-95256	HCC
120	25x3	150	CB4-C-120253	HCC
	25x5	150	CB4-C-120255	HCC
	25x6	200	CB4-C-120256	HCC
150	25x3	150	CB4-C-150253	HCC
	25x5	200	CB4-C-150255	HCC
	40x5	250	CB4-C-150405	HCC
185	30x5	200	CB4-C-185305	HCC
	40x5	250	CB4-C-185405	HCC
	50x5	150x2	CB4-D-185505	HCD
240	30x4	250	CB4-D-240304	HCD
	30x5	150x2	CB4-D-240305	HCD
	50x6	150x2	CB4-D-240506	HCD
300	50x6	200x2	CB4-D-300506	HCD
	50x8	200x2	CB4-D-300508	HCD

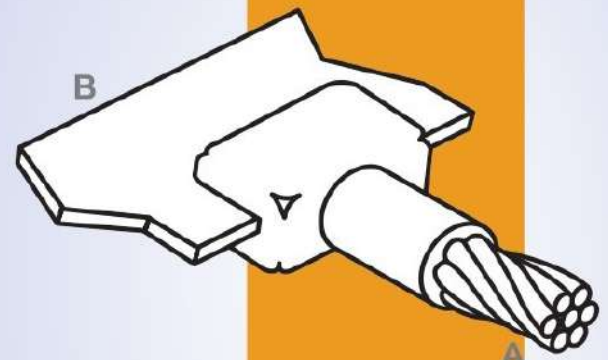

Tools Request :



Mould



Mould brush



Handle clamp



Scraper



Metal powder



Steel disk



Flint igniter



Bus bar brush

CB5

Cable to Bus Bar
Horizontal bus tap
to horizontal cable run



Conductor Size		Metal Powder (g)	Graphite Mould Type	Handle Clamp Type
A mm ²	B mm ²			
	20x2	45	CB5-N-16202	HCN
16	20x3	65	CB5-N-16203	HCN
	25x4	65	CB5-N-16254	HCN
25	20x2	45	CB5-N-25202	HCN
	20x3	65	CB5-N-25203	HCN
	25x4	65	CB5-N-25254	HCN
35	20x2	65	CB5-N-35202	HCN
	20x3	90	CB5-N-35203	HCN
	25x3	90	CB5-N-35253	HCN
50	25x3	90	CB5-N-50253	HCN
	25x4	115	CB5-N-50254	HCN
	25x5	115	CB5-N-50255	HCN
70	25x3	115	CB5-N-70253	HCN
	25x4	115	CB5-N-70254	HCN
	25x5	150	CB5-C-70255	HCC
95	25x3	115	CB5-C-95253	HCC
	25x5	150	CB5-C-95255	HCC
	25x6	150	CB5-C-95256	HCC
120	25x3	150	CB5-C-120253	HCC
	25x5	150	CB5-C-120255	HCC
	25x6	200	CB5-C-120256	HCC
150	25x3	150	CB5-C-150253	HCC
	25x5	200	CB5-C-150255	HCC
	40x5	250	CB5-C-150405	HCC
185	30x5	200	CB5-C-185305	HCC
	40x5	250	CB5-C-185405	HCC
	50x5	150x2	CB5-D-185505	HCD
240	30x4	250	CB5-D-240304	HCD
	30x5	150x2	CB5-D-240305	HCD
	50x6	150x2	CB5-D-240506	HCD
300	50x6	200x2	CB5-D-300506	HCD
	50x8	200x2	CB5-D-300508	HCD

Tools Request :



Rod Size	Conductor Size	Metal Powder (g)	Graphite Mould Type	Handle Clamp Type
A _{mm}	B _{mm²}			
16	20x2	45	CB26-N-16202	HCN
	20x3	65	CB26-N-16203	HCN
	25x4	65	CB26-N-16254	HCN
25	20x2	45	CB26-N-25202	HCN
	20x2	65	CB26-N-25203	HCN
	25x4	65	CB26-N-25254	HCN
35	20x2	65	CB26-N-35202	HCN
	20x3	90	CB26-N-35203	HCN
	25x3	90	CB26-N-35253	HCN
50	25x3	90	CB26-N-50253	HCN
	25x4	115	CB26-N-50254	HCN
	25x5	115	CB26-N-50255	HCN
70	25x3	115	CB26-N-70253	HCN
	25x4	115	CB26-N-70254	HCN
	25x5	150	CB26-C-70255	HCC
95	25x3	115	CB26-N-95253	HCN
	25x5	150	CB26-C-95255	HCC
	25x6	150	CB26-C-95256	HCC
120	25x3	150	CB26-C-120253	HCC
	25x5	150	CB26-C-120255	HCC
	25x6	200	CB26-C-120256	HCC
150	25x3	150	CB26-C-150253	HCC
	25x5	200	CB26-C-150255	HCC
	25x6	250	CB26-C-150256	HCC
185	25x3	200	CB26-C-185253	HCC
	25x5	250	CB26-C-185255	HCC
	25x6	150x2	CB26-D-185256	HCD
240	25x3	250	CB26-D-240253	HCD
	25x5	150x2	CB26-D-240255	HCD
	25x6	150x2	CB26-D-240256	HCD
300	25x6	200x2	CB26-D-300256	HCD
	25x8	200x2	CB26-D-300258	HCD

CB26

Cable to Bus Bar
Horizontal cable terminal
to horizontal cable run

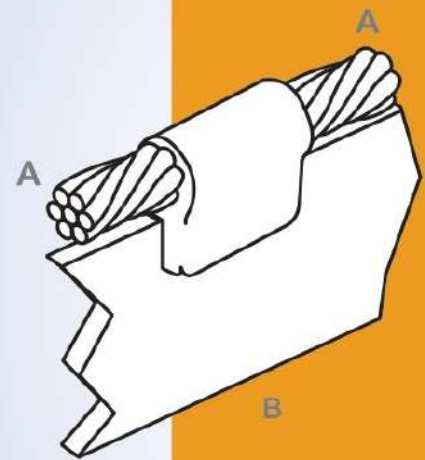

Tools Request :



Mould



Mould brush



Handle clamp



Scraper



Metal powder



Steel disk



Flint igniter



Bus bar brush

CA1

Cathodic Protection
Horizontal thru cable
to horizontal pipe

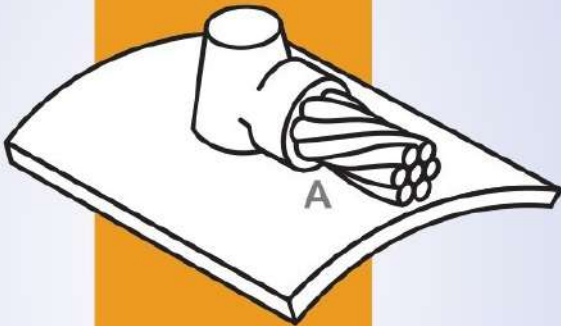

Conductor A _{mm²}	Metal Powder (g)	Graphite Mould Type	Handle Clamp Type
2.5	15	CA1-A-2.5	HCA
4	15	CA1-A-4	HCA
6	15	CA1-A-6	HCA
10	15	CA1-A-10	HCA
16	15	CA1-A-16	HCA
25	15	CA1-A-25	HCA
35	32	CA1-A-35	HCA
50	65	CA1-A-50	HCA
70	65	CA1-A-70	HCA

CA2

Cathodic Pro
Horizontal thru cable
to horizontal pipe

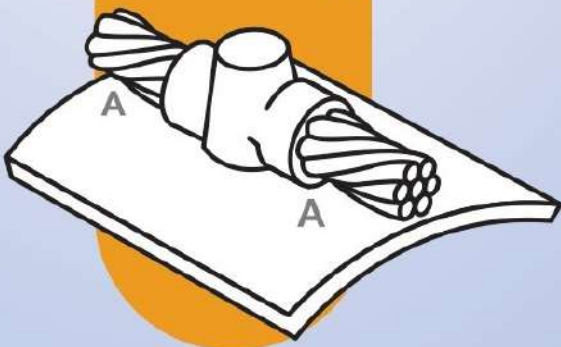

Conductor A _{mm²}	Metal Powder (g)	Graphite Mould Type	Handle Clamp Type
2.5	25	CA2-A-2.5	HCA
4	25	CA2-A-4	HCA
6	25	CA2-A-6	HCA
10	25	CA2-A-10	HCA
16	25	CA2-A-16	HCA
25	25	CA2-A-25	HCA
35	45	CA2-A-35	HCA
50	65	CA2-A-50	HCA
70	65	CA2-A-70	HCA

Tools Request :



RR1

Ground Rod to Ground Rod

Vertical ground rod end to end



Rod Size (A)		Metal Powder (g)	Graphite Mould Type	Handle Clamp Type
mm	inch			
12.7	1/2	150	RR1- E -127127	HCC
14.2	5/8	200	RR1- E -142142	HCC
17.2	3/4	200	RR1- E -172172	HCC
23.1	1	250	RR1- E -231231	HCC

RR2

Ground Rod to Ground Rod

Horizontal ground rod end to end

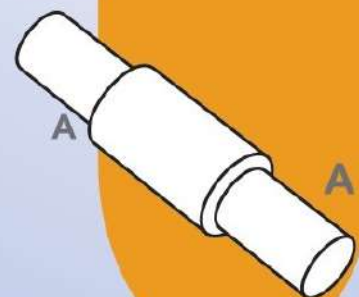

Rod Size (A)		Metal Powder (g)	Graphite Mould Type	Handle Clamp Type
mm	inch			
12.7	1/2	150	RR2-C-127127	HCC
14.2	5/8	200	RR2-C-142142	HCC
17.2	3/4	200	RR2-C-172172	HCC
23.1	1	250	RR2-C-231231	HCC

Tools Request :



RR3

Ground Rod to Ground Rod

Horizontal ground rod tap to vertical ground rod

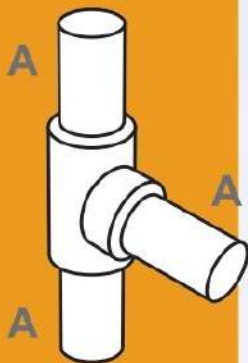

Rod Size (A)		Metal Powder (g)	Graphite Mould Type	Handle Clamp Type
mm	inch			
12.7	1/2	200	RR3-E -127127	HCC
14.2	5/8	200	RR3-E -142142	HCC
17.2	3/4	250	RR3-E -172172	HCC
23.1	1	2 x 150	RR3-D-231231	HCD

RR4

Ground Rod to Ground Rod

Horizontal ground rod to ground rod



Rod Size (A)		Metal Powder (g)	Graphite Mould Type	Handle Clamp Type
mm	inch			
12.7	1/2	200	RR4-C-127127	HCC
14.2	5/8	200	RR4-C-142142	HCC
17.2	3/4	250	RR4-C-172172	HCC
23.1	1	2 x 150	RR4-D-231231	HCD

Tools Request :





GOLDWELD

Exothermic Welding

CÔNG TY TNHH SẢN PHẨM VÀ DỊCH VỤ CÔNG NGHIỆP VÀ CÔNG NGHỆ MỚI VIỆT NAM
CÔNG TY TNHH SẢN PHẨM VÀ DỊCH VỤ CÔNG NGHIỆP VÀ CÔNG NGHỆ MỚI VIỆT NAM
Số 10 Đường số 1, Khu Công Nghiệp Tân Phú, Quận Tân Phú, TP. Hồ Chí Minh
Số 10 Đường số 1, Khu Công Nghiệp Tân Phú, Quận Tân Phú, TP. Hồ Chí Minh

CHỨC VỤ CÔNG VIỆC

Tên người phụ trách: Ông Nguyễn Văn Tuấn
Số người phụ trách: 01 người
Số người phụ trách: 01 người
Số người phụ trách: 01 người

MÔ TẢ CÔNG VIỆC

1. Tên công việc: Lắp đặt hệ thống hàn nhiệt
2. Mục đích: Lắp đặt hệ thống hàn nhiệt để phục vụ cho việc thi công công trình
3. Địa điểm: Tại công trường thi công công trình
4. Thời gian: Từ ngày 01/01/2023 đến ngày 31/01/2023

Người phụ trách: Nguyễn Văn Tuấn
Người phụ trách: Nguyễn Văn Tuấn

CÔNG TY TNHH SẢN PHẨM VÀ DỊCH VỤ CÔNG NGHIỆP VÀ CÔNG NGHỆ MỚI VIỆT NAM
CÔNG TY TNHH SẢN PHẨM VÀ DỊCH VỤ CÔNG NGHIỆP VÀ CÔNG NGHỆ MỚI VIỆT NAM
Số 10 Đường số 1, Khu Công Nghiệp Tân Phú, Quận Tân Phú, TP. Hồ Chí Minh
Số 10 Đường số 1, Khu Công Nghiệp Tân Phú, Quận Tân Phú, TP. Hồ Chí Minh

CHỨC VỤ CÔNG VIỆC

Tên người phụ trách: Ông Nguyễn Văn Tuấn
Số người phụ trách: 01 người
Số người phụ trách: 01 người
Số người phụ trách: 01 người

MÔ TẢ CÔNG VIỆC

1. Tên công việc: Lắp đặt hệ thống hàn nhiệt
2. Mục đích: Lắp đặt hệ thống hàn nhiệt để phục vụ cho việc thi công công trình
3. Địa điểm: Tại công trường thi công công trình
4. Thời gian: Từ ngày 01/01/2023 đến ngày 31/01/2023

Người phụ trách: Nguyễn Văn Tuấn
Người phụ trách: Nguyễn Văn Tuấn



GOLDWELD

Exothermic Welding



For more information, Please visit and contact

DONG NAM INDUSTRIAL AND TRADING JSC.,
16/322E Le Trong Tan Street, Thanh Xuan District, Ha Noi, Viet Nam
Website: www.chongsetdongnam.com
Email: sale.dongnam@gmail.com