

10K Ball Valve Full Bore

10STBF
10STLBF (Gas service)
 FF-flanged



Test Pressure

Code	10STBF	10STLBF
Body	2.06MPa (21kgf/cm ²) [hydrostatic]	2.06MPa (21kgf/cm ²) [hydrostatic]
Seat	0.59MPa (6kgf/cm ²) [air]	1.28MPa (13kgf/cm ²) [air]

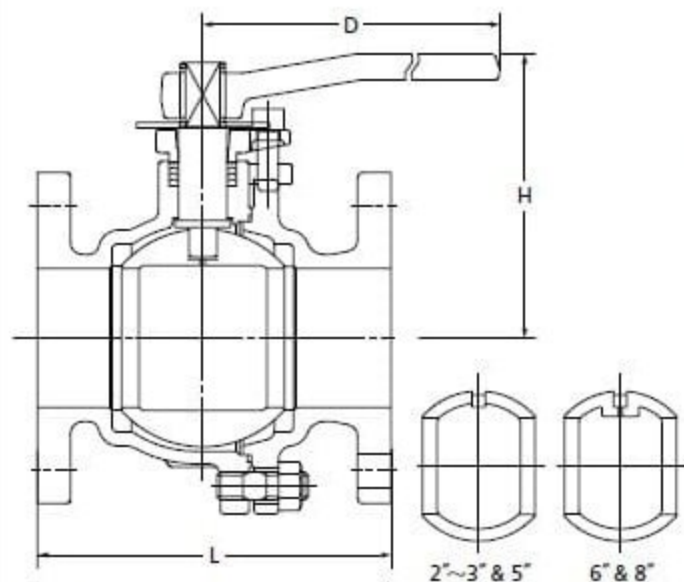

F-F dimension : ASME B16.10
 End flanges : JIS B 2239 10K

Maximum Service Pressure

Code	Valve size	Temperature	Pressure
10STBF	All size	120°C W.O.G.	1.37MPa
	4" and smaller	160°C W.O.G.	0.98MPa
	5" to 8"	140°C W.O.G.	0.98MPa
10STLBF	All size	80°C gas	1.18MPa

● Use for lubricating or hydraulic oil is acceptable.

Materials

Parts	JIS material
Body	FCD-S
Body cap	FCD-S
Stem	SUS 403
Ball	SUS 304 / SCS 13A / SUS 304TP
Gland	FCD-S
Gland packing	PTFE
Handle	FCD 400
Gasket	PTFE
Packing washer	SUS 304 (1/2" ~ 1 1/4")
Ball seat	HYPATITE PTFE* ¹
Cap bolt / nut	SS 400* ²
Gland bolt	SCM 435
O ring* ³	NBR
Stopper	SUS 430
Name plate* ³	SUS 304

*¹ PTFE or C/F PTFE is optionally available.

*² Different bolt / nut material is required for service exceeding temperature range of 0~225°C.
 Contact KITZ Corporation for technical advice.

*³ for 10STLB only
 Contact KITZ Corporation for use of valve actuators.

Dimensions

Size	mm	15	20	25	32	40	50	65	80	100	125	150	200
	inch	1/2	3/4	1	1 1/4	1 1/2	2	2 1/2	3	4	5	6	8
L		108	117	127	140	165	178	190	203	229	356	394	457
H		106	109	130	135	115	120	153	162	199	219	293	352
D		130	130	160	160	230	230	400	400	460	460	1000	1500

NOTE : For flange dimensions refer to Page 40. ※RF-flanged ends shall be optionally available.