

TD-10NA·30NA

Features

1. Bimetal solves air-binding problem and ensures a smooth discharge of cold condensate or air at the start of operation, enabling steam equipment to efficiently start to run.
2. The stainless steel valve disc and valve seat, which are subjected to special heat treatment, offers excellent durability.
3. The valve disc, valve seat and bimetal can be replaced on site without disconnecting the steam trap from the piping.
4. Easy maintenance and inspection due to simple structure: the valve disc is only movable part.
5. Compact, lightweight and inexpensive. Applicable in wide working pressure range and adjustment-free.
6. Installable in any direction and easy to plumb.
7. Free of improper operation and steam leakage due to air insulation type.
8. Built-in strainer eliminates requirement for strainer before the product.
9. Large discharge capacity.



TD-10NA



TD-30NA

Specifications

Model		TD-10NA	TD-30NA	
Nominal size		15-25A		
Application		Steam condensate		
Working pressure		0.035-2.0 MPa	0.035-1.0 MPa	0.035-2.0 MPa
Allowable back pressure		50% or less of inlet pressure		
Max. temperature		220°C		
Connection		JIS Rc screwed	JIS 10K FF flanged	JIS 20K FF flanged
Material	Body	Ductile cast iron		
	Disc, seat	Stainless steel (special heat treatment)		

Dimensions (mm) and Weights (kg)

●TD-10NA

Nominal size	d	L	H ₁	H ₂	Weight
15A	Rc 1/2	90	49	55.5	0.9
20A	Rc 3/4	90	53	60.5	1.2
25A	Rc 1	90	56	62.5	1.4

●TD-30NA

Nominal size	L	H ₁	H ₂	Weight
15A	125	51	59	2.3
20A	140	54	63	3.4
25A	150	65	63	4.1

- The dimensions of the product with JIS 10K FF flanged and the product with JIS 20K FF flanged are identical.
- The thickness of JIS 10K FF flanges conforms to that of JIS 20K FF flanges.

Maximum Continuous Discharge Capacity Chart

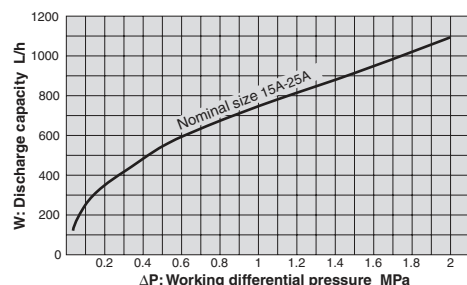

- The discharge capacity shown in the chart on the left is the maximum value. In designing a system, select a steam trap with a sufficient safety factor (four to five times the regular level). That is, for example, if a discharge capacity of 100 kg/h is required, select a steam trap capable of discharging 400 to 500 kg/h.

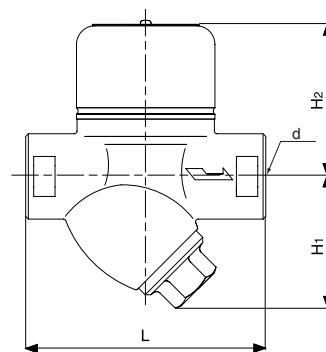

TD-10NA

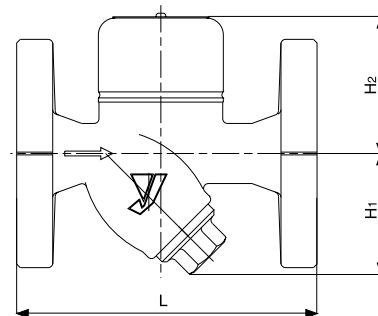

TD-30NA

Installation Posture

The steam trap can be installed horizontally, sidlingly, or vertically.

